



[electrolux.com/shop](http://electrolux.com/shop)



Electrolux Appliances AB  
S:t Göransgatan 143  
S-105 45 Stockholm  
Sweden

[www.electrolux.com](http://www.electrolux.com)



Ultrapower®  
Cordless vacuum cleaner



<b>GB</b>	INSTRUCTION BOOK.....	4	<b>GR</b>	ΕΓΧΕΙΡΙΔΙΟ ΟΔΗΓΙΩΝ.....	34	<b>RO</b>	MANUAL DE INSTRUCȚIUNI.....	64
<b>FR</b>	MODE D'EMPLOI.....	7	<b>HR</b>	KNJIŽICA S UPUTAMA.....	37	<b>RU</b>	ИНСТРУКЦИЯ.....	67
<b>AR</b>	دليل المستخدم.....	10	<b>HU</b>	HASZNÁLATI ÚTMUTATÓ.....	40	<b>SK</b>	NÁVOD NA POUŽITIE.....	70
<b>BG</b>	БРОШУРА С ИНСТРУКЦИИ.....	13	<b>IT</b>	ISTRUZIONI.....	43	<b>SL</b>	NAVODILA.....	73
<b>CZ</b>	NÁVOD K POUŽITÍ.....	16	<b>LT</b>	INSTRUKCIJŲ KNYGA.....	46	<b>SR</b>	UPUTSTVO.....	76
<b>DA</b>	VEJLEDNING.....	19	<b>LV</b>	LIETOŠANAS INSTRUKCIJA.....	49	<b>SV</b>	BRUKSANVISNING.....	79
<b>DE</b>	GEBRAUCHSANWEISUNG.....	22	<b>NL</b>	INSTRUCTIE BOEK.....	52	<b>TR</b>	EL KİTABI.....	82
<b>EE</b>	KASUTUSJUHEND.....	25	<b>NO</b>	BRUKSANVISNING.....	55	<b>UA</b>	ПОСІБНИК КОРИСТУВАЧА.....	85
<b>ES</b>	LIBRO DE INSTRUCCIONES.....	28	<b>PL</b>	INSTRUKCJA OBSŁUGI.....	58			
<b>FI</b>	OHJEKIRJA.....	31	<b>PT</b>	LIVRO DE INSTRUÇÕES.....	61			

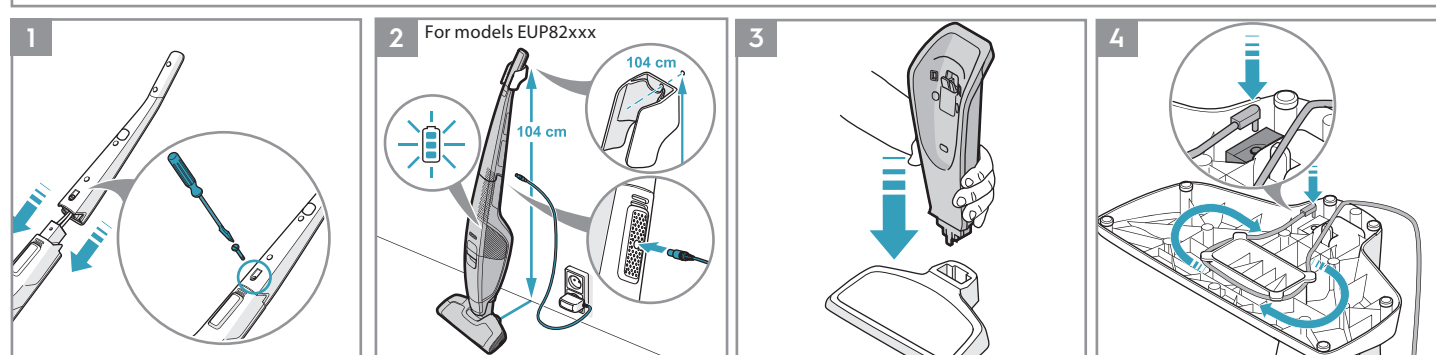
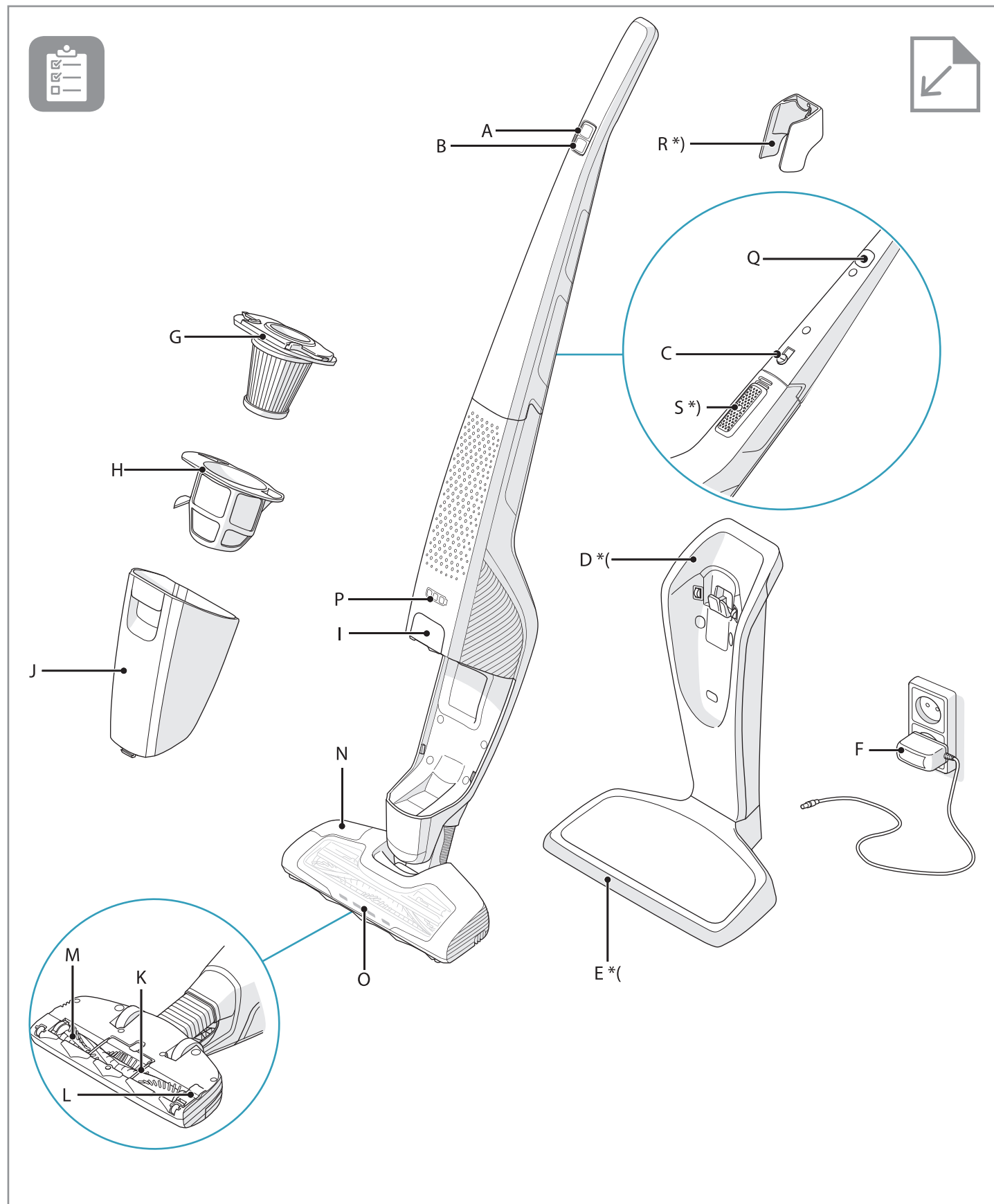

GB

FR

AR

BG

CZ

DA

DE

EE

ES

FI

GR

HR

HU

IT

LT

LV

NL

NO

PL

PT

RO

RU

SK

SL

SR

SV

TR

UA

ENGLISH

Thank you for choosing an Electrolux Ultrapower® vacuum cleaner. In order to ensure the best results, always use original Electrolux accessories and spare parts. They have been designed especially for your vacuum cleaner. This product is designed with the environment in mind. All plastic parts are marked for recycling purposes.

DESCRIPTION OF ULTRAPOWER®

- |                                     |                               |
|-------------------------------------|-------------------------------|
| A. ON/OFF button                    | K. Cable protector grill      |
| B. Power regulation button          | L. Hatch cover for brush roll |
| C. Locking screw                    | M. Brush roll                 |
| D. Charging station, wall unit (*)  | N. BRUSHROLLCLEAN® pedal      |
| E. Charging station, floor unit (*) | O. Nozzle front lights        |
| F. Charging adapter                 | P. Charging indicator         |
| G. Fine filter (inner filter)       | Q. Cliff hanger               |
| H. Pre filter (outer filter)        | R. Wall holder (*)            |
| I. Release button, dust container   | S. Charging connector(*)      |
| J. Dust container                   |                               |

(\*) Not available on models EUP82xxx      \*) Only on models EUP82xxx.

BEFORE STARTING

Check that the package includes all parts described in this instruction manual and read this manual carefully. Pay special attention to the safety precautions chapter. Save these instructions.

- Assemble the handle.
- For model EUP82xx, use the wall holder (\*):  
A) Make sure that Ultrapower® is on a stable and horizontal surface away from heat sources, direct sunlight or wet places. Attach the wall holder to the wall 104 cm above the floor with a suitable screw and wall plug. Make sure to use a correct wall plug for the wall.  
B) Attach the handle to the wall holder.  
C) Connect the charging cable to the back side of the vacuum cleaner.

For all other models:

- Assemble the charging stand.
- A) Connect the charging cable to the charge stand.  
B) There is a hollow space in the bottom of the charging station where unused cable can be wound.  
C) Position the charging station on a stable and horizontal surface away from heat sources, direct sunlight or wet places.
- Insert the adaptor into the mains and charge Ultrapower®. The charging indicator will be lit when Ultrapower® is on charge.

CHARGING ULTRAPOWER®

- When fully charged, the charging indicator will blink slowly. The numbers of LED lamps will indicate the level of charge. Full charging time is around 5 hours. For better battery performance, charge Ultrapower® for 24 hours before first use and always keep it on charge when not used.

VACUUMING WITH ULTRAPOWER®

Before vacuuming, check that the nozzle wheels and the brush roll are clean from sharp objects in order to avoid scratching sensitive floors and to ensure full cleaning performance.

- Start and stop Ultrapower® by pushing the ON/OFF button. Ultrapower® has 3 power settings which is regulated with the power regulation button. Ultrapower® will start on the "High power mode". For more silent cleaning and longest run time, press the power regulation button to activate the "Long runtime mode". Press the power regulation button one more time to activate the "Normal cleaning mode".

BRUSHROLLCLEAN® FUNCTION

Use the BRUSHROLLCLEAN® function to keep the brush roll clean and free from hair and fibres. For best results use the BRUSHROLLCLEAN® function when Ultrapower® is fully charged.

- Place Ultrapower® on a hard and flat surface. Do not use the BRUSHROLLCLEAN® function on carpets. Press the BRUSHROLLCLEAN® pedal with your foot while the cleaner is on. Hold for 5 seconds until hairs and fibres are removed. There will be a cutting noise during this process, this is normal. If hairs remain on the brush roll, repeat the process. The BRUSHROLLCLEAN® function is equipped with an overheating protection. If the BRUSHROLLCLEAN® function has been used for more

than 30 seconds (constant or interrupted) it will deactivate the brush roll and turn off the nozzle front lights. The vacuum cleaner can still be used, even when the BRUSHROLLCLEAN® function is deactivated. To reactivate the BRUSHROLLCLEAN® function, place Ultrapower® on charge and charge for 15 minutes. Please note that the BRUSHROLLCLEAN® function might not be able to remove thicker threads or wires that are caught in the brush roll.

EMPTYING OF THE DUST CONTAINER

- Remove the dust container by pressing the button.
- Take out the filters from the dust container by pressing the release buttons. Empty the contents into a dustbin. Never wash the dust container or filters in a dishwasher.

IMPORTANT - FILTER CLEANING!

- The filters must be cleaned at regular intervals to ensure a high cleaning performance. Take out the filters by pressing the release buttons. Separate the inner filter from the outer filter.
- Rinse the filter parts carefully under lukewarm water without using any detergents. (Never use the dishwasher or washing machine.) Shake to remove excess water and leave to dry minimum 12h before putting them back into the cleaner.

CLEANING THE HOSE AND NOZZLE WHEELS

- Loosen the hose behind the nozzle from its upper connection. Remove any object or debris that can be blocking the airflow in the hose or in the air channel to the dust cup, and put the hose back.
- If the wheels need to be cleaned or get jammed, remove them carefully by using a flat screwdriver.

REMOVING AND CLEANING THE BRUSH ROLL

- If the brushroll gets blocked Ultrapower® will stop. Open the cable protector grill and the brush roll hatch cover and remove the brush roll.
- Use a pair of scissors to remove threads etc. Reassemble the brush roll, making sure it can spin freely.

REMOVING THE BATTERIES FOR RECYCLING

**Warning: Battery removal must only be done by an Electrolux service center or official collection point!**

- Only remove batteries if the product is to be scrapped. Improper handling of the batteries may be hazardous. **Batteries should always be completely discharged before removal.** Take your product to an Electrolux service center or official collection point for recycling. They can remove and recycle the battery and electric parts in a safe and professional way. Follow your country's rules for collection of rechargeable batteries and electrical products.

Enjoy a great cleaning experience with Ultrapower®!

Electrolux reserves the right to change products, information and specifications without notice.

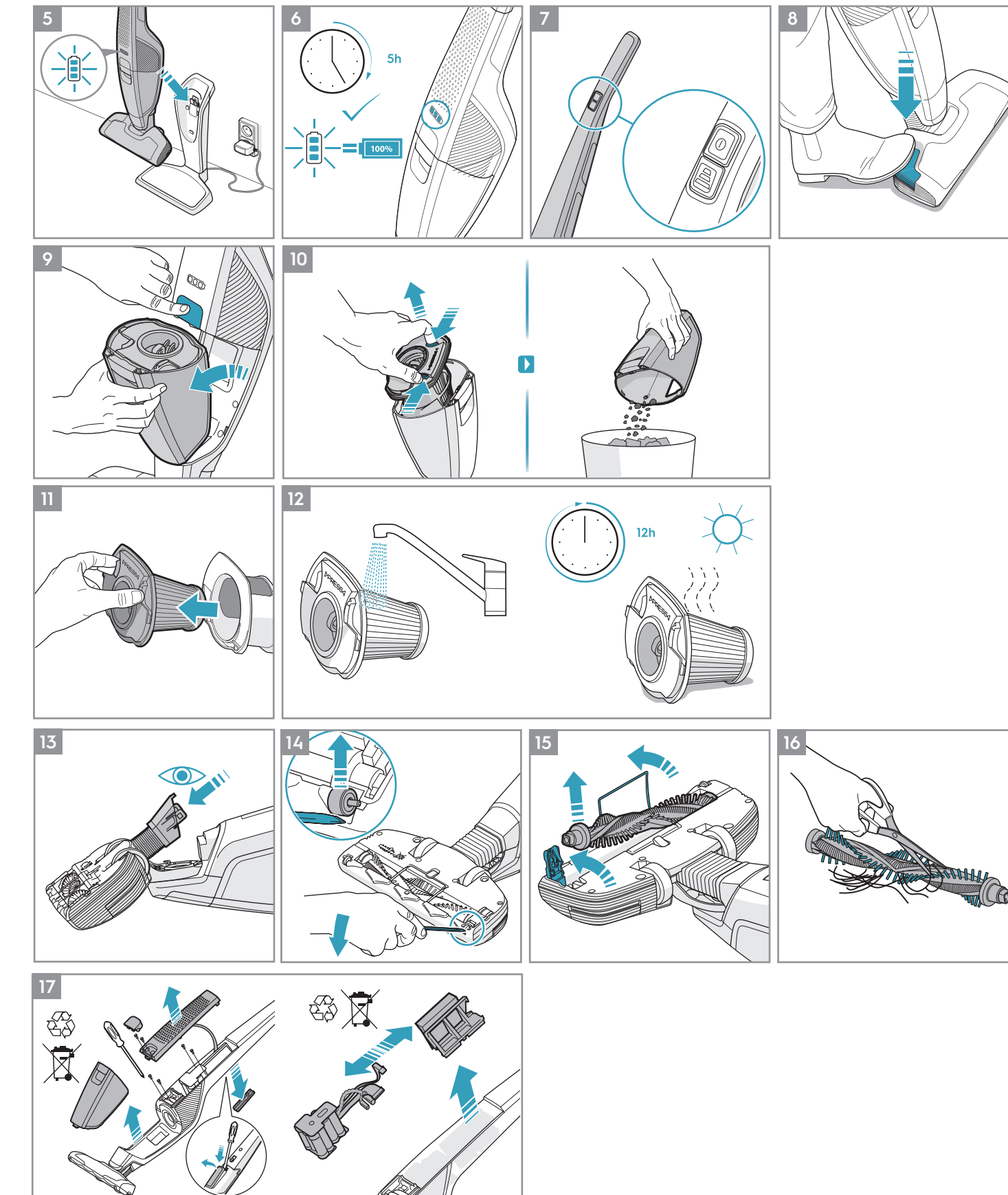

## SAFETY PRECAUTIONS

This appliance can be used by children aged from 8 years and above and persons with reduced physical, sensory or mental capabilities or lack of experience and knowledge if they have been given supervision or instruction concerning use of the appliance in a safe way and understand the hazards involved.

Children shall not play with the appliance.

Cleaning and maintenance shall not be made by children without supervision.

Batteries must be removed from the appliance before it is scrapped.

The battery is to be disposed of safely.

For the purposes of recharging the battery, only use the charging adapter provided with the product.

Ultrapower® should only be used for normal vacuuming indoors and in a domestic environment. Make sure it is stored in a dry place. Packaging material, e.g. plastic bags should not be accessible to children to avoid suffocation.

### Never use the vacuum cleaner:

- In wet areas.
- Close to flammable gases, etc.
- When the product shows visible signs of damage.
- On sharp objects or liquids.
- On hot or cold cinders, lighted cigarette butts, etc.
- On fine dust, for instance from plaster, concrete, flour, hot or cold ashes.

### Caution:

- Do not leave the vacuum cleaner in direct sunlight.
- Avoid exposing the vacuum cleaner to strong heat.
- The battery cells within must not be dismantled, short circuited or placed against a metal surface.
- Never use the vacuum cleaner without its filters.
- Do not try to touch the brush roll while the cleaner is switched on and the brush roll is turning.
- Mind your fingers if cleaning the inside of the floor nozzle. The metal blade of the BRUSHROLLCLEAN® function is sharp and could cause injury.

**Using the vacuum cleaner in the above circumstances may cause serious personal injury or damage to the product. Such injury or damage is not covered by the warranty or by Electrolux.**

## SERVICING AND WARRANTY

All service or repairs must be carried out by an authorized Electrolux service centre.

This warranty does not cover reduction in battery runtime due to battery age or use, as the life of the battery depends upon the amount and nature of use.









### To protect the motor, battery and electronics the product should not be stored or operated in:

- An ambient temperature below 5 °C or exceeding 35 °C. If the product is stored in a temperature below 5 °C or exceeding 35 °C, let the product cool down or warm up and dry for a few hours before usage.
- A humidity level below 20% or exceeding 80% (non-condensing).

If the product is stored for an extended time period (without usage or continuous charging), we recommend to store the product in normal room temperature with the batteries charged at 50% capacity or more. This will maintain the performance of the product.

**Attention!** Dew condensation may form inside the product if the unit is moved from a cold to a warm environment or after heating up the storage room. Wait a few hours for the internal components to warm up and dry before usage.

## INDICATION LAMPS

CHARGING 	WHAT DOES IT MEAN?	DURING USAGE	WHAT DOES IT MEAN?
	Blink slowly = 100 % fully charged		75 - 100 % capacity
	50 - 95 % charged		50- 75 % capacity remaining
	0 - 50 % charged		25 - 50 % capacity remaining
			Ultrapower® needs to be recharged.

# Obsah je uzamčen

**Dokončete, prosím, proces objednávky.**

**Následně budete mít přístup k celému dokumentu.**



**Proč je dokument uzamčen? Nahněvat Vás rozhodně nechceme. Jsou k tomu dva hlavní důvody:**

- 1) Vytvořit a udržovat obsáhlou databázi návodů stojí nejen spoustu úsilí a času, ale i finanční prostředky. Dělali byste to Vy zadarmo? Ne\*. Zakoupením této služby obdržíte úplný návod a podpoříte provoz a rozvoj našich stránek. Třeba se Vám to bude ještě někdy hodit.

*\*) Možná zpočátku ano. Ale vězte, že dotovat to dlouhodobě nelze. A rozhodně na tom nezbohatneme.*

- 2) Pak jsou tady „roboti“, kteří se přiživují na naší práci a „vysávají“ výsledky našeho úsilí pro svůj prospěch. Tímto krokem se jim to snažíme překazit.

A pokud nemáte zájem, respektujeme to. Urgujte svého prodejce. A když neuspějete, rádi Vás uvidíme!