

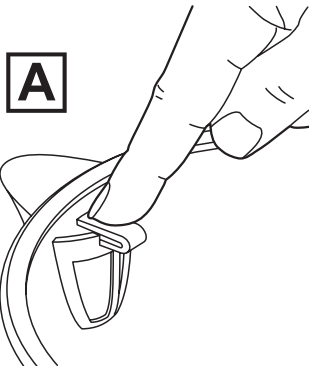

# Russell Hobbs

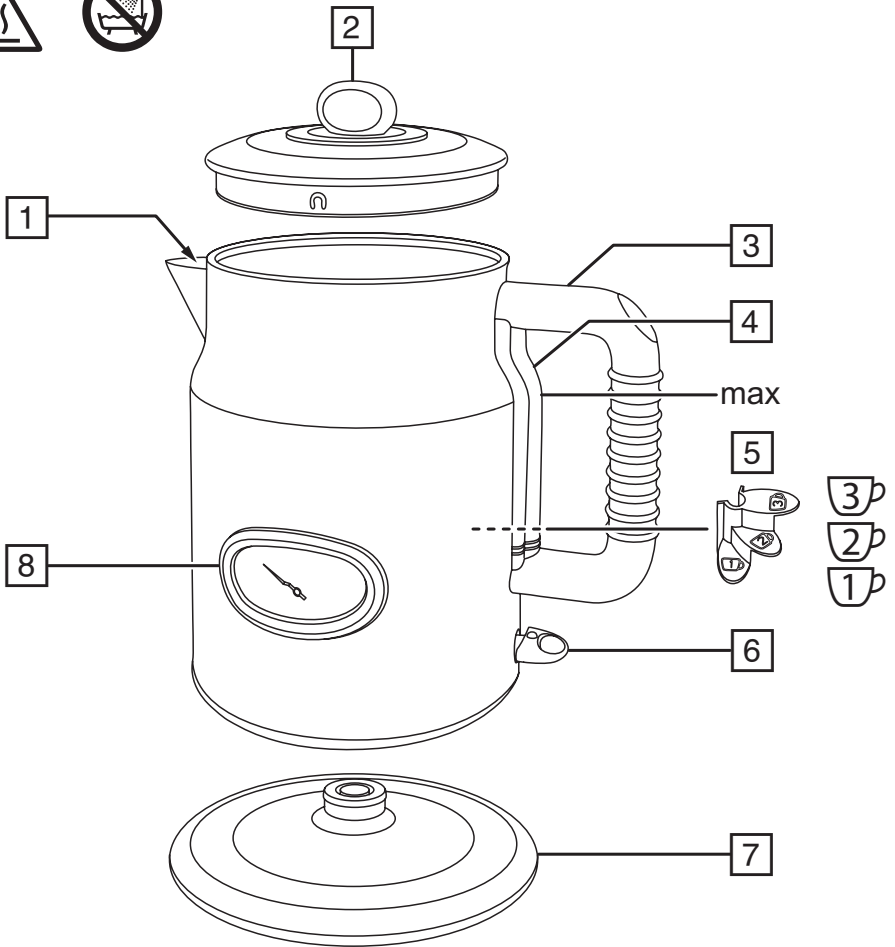

instructions	3	pokyny (Čeština)	27
Bedienungsanleitung	5	pokyny (Slovenčina)	29
mode d'emploi	7	instrukcija	31
instructies	9	upute	33
istruzioni per l'uso	11	navodila	35
instrucciones	13	οδηγίες	37
instruções	15	utasítások	39
brugsanvisning	17	talimatlar	41
bruksanvisning (Svenska)	19	instrucțiuni	43
bruksanvisning (Norsk)	21	инструкции (Български)	45
käyttöohjeet	23	تعليمات الاستخدام	47
инструкции (Русский)	25		



Read the instructions, keep them safe, pass them on if you pass the appliance on. Remove all packaging before use.

## IMPORTANT SAFEGUARDS

Follow basic safety precautions, including:

This appliance can be used by children aged from 8 years and above and persons with reduced physical, sensory or mental capabilities or lack of experience and knowledge if they have been supervised/instructed and understand the hazards involved. Children shall not play with the appliance.

Cleaning and user maintenance shall not be done by children unless they are older than 8 and supervised.

Keep the appliance and cable out of reach of children under 8 years.

 Parts of the appliance will get hot during use.

If you overfill, the kettle may spit boiling water.

Use the kettle only with the stand supplied (and vice versa).

If the cable is damaged, it must be replaced by the manufacturer, its service agent, or someone similarly qualified, to avoid hazard.

- Don't put the kettle, stand, cable, or plug in any liquid.
- Don't use the kettle for any purpose other than heating water.
- Don't operate the appliance if it's damaged or malfunctions.

## HOUSEHOLD USE ONLY

### DIAGRAMS

- |                      |                            |
|----------------------|----------------------------|
| 1. Filter            | 5. Rapid boil zones marker |
| 2. Lid               | 6. Switch/light            |
| 3. Handle            | 7. Stand                   |
| 4. Water level gauge | 8. Water temperature gauge |

### BEFORE USING FOR THE FIRST TIME

Fill to **max**, boil, discard the water, then rinse. Do this twice to remove any manufacturing dust, etc.

### FILLING

1. Remove the lid.
2. Fill with at least 1 cup of water, but not above max.
3. If you want only 1, 2, or 3 cups of water, fill to the 1, 2, or 3 marks inside the kettle.
4. Refit the lid. Always fit the lid when boiling the kettle.

### USING YOUR KETTLE

1. Put the stand on a stable, level surface.
2. Plug the stand into the wall socket.
3. Put the kettle on the stand.
4. Move the switch to I.
5. The light will come on. The kettle will start to heat.
6. When the water boils the kettle will switch off.
7. To switch off manually, move the switch to **O**, or simply lift the kettle off the stand.

### WATER TEMPERATURE GAUGE

The water temperature gauge constantly shows you the temperature of the water inside the kettle. Use the gauge when you are making drinks that require different water temperatures like green teas, white teas, coffee, etc. The gauge will not work if there is insufficient water in the kettle (minimum 1 cup).

# Obsah je uzamčen

**Dokončete, prosím, proces objednávky.**

**Následně budete mít přístup k celému dokumentu.**



**Proč je dokument uzamčen? Nahněvat Vás rozhodně nechceme. Jsou k tomu dva hlavní důvody:**

- 1) Vytvořit a udržovat obsáhlou databázi návodů stojí nejen spoustu úsilí a času, ale i finanční prostředky. Dělali byste to Vy zadarmo? Ne\*. Zakoupením této služby obdržíte úplný návod a podpoříte provoz a rozvoj našich stránek. Třeba se Vám to bude ještě někdy hodit.

*\*) Možná zpočátku ano. Ale vězte, že dotovat to dlouhodobě nelze. A rozhodně na tom nezbohatneme.*

- 2) Pak jsou tady „roboti“, kteří se přiživují na naší práci a „vysávají“ výsledky našeho úsilí pro svůj prospěch. Tímto krokem se jim to snažíme překazit.

A pokud nemáte zájem, respektujeme to. Urgujte svého prodejce. A když neuspějete, rádi Vás uvidíme!