

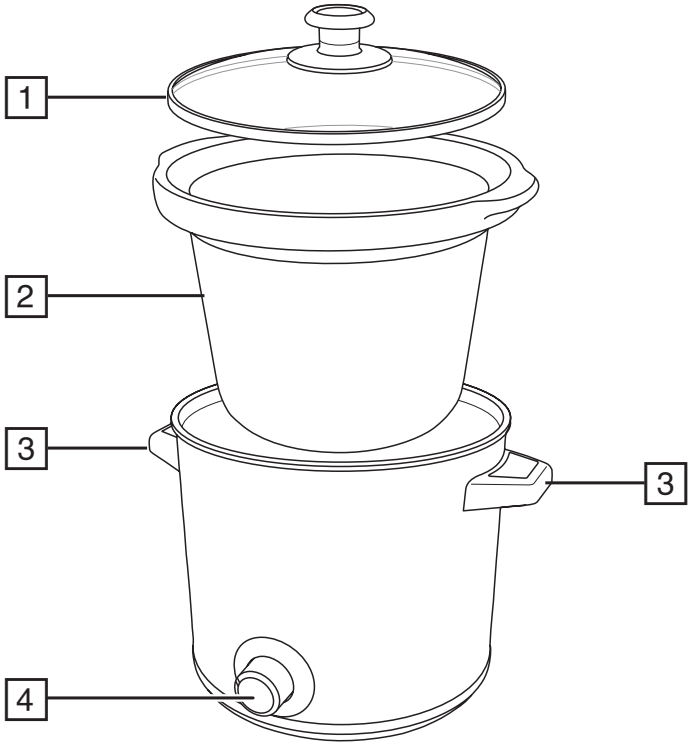

# Russell Hobbs



instructions	3	pokyny (Čeština)	39
Bedienungsanleitung	6	pokyny (Slovenčina)	42
mode d'emploi	9	instrukcja	45
instructies	12	upute	48
istruzioni per l'uso	15	navodila	51
instrucciones	18	οδηγίες	54
instruções	21	utasítások	57
brugsanvisning	24	talimatlar	60
bruksanvisning (Svenska)	27	instrucțiuni	63
bruksanvisning (Norsk)	30	инструкции (Български)	66
käyttöohjeet	33	تعليمات الاستخدام	69
инструкции (Русский)	36		



**A**

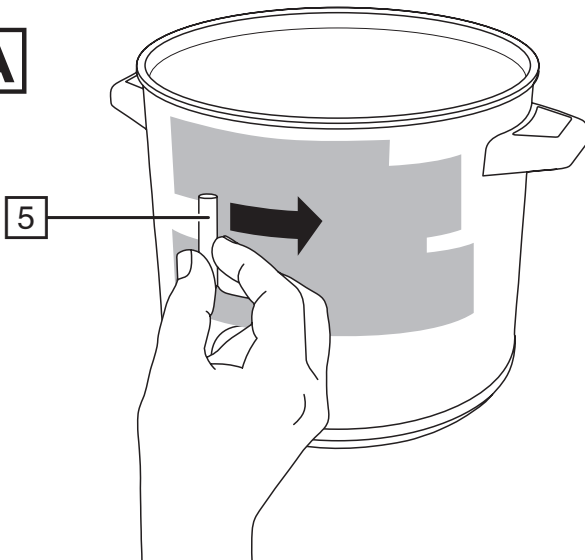

Read the instructions, keep them safe, pass them on if you pass the appliance on. Remove all packaging before use.

## IMPORTANT SAFEGUARDS

Follow basic safety precautions, including:

This appliance can be used by children aged from 8 years and above and persons with reduced physical, sensory or mental capabilities or lack of experience and knowledge if they have been supervised/instructed and understand the hazards involved. Children shall not play with the appliance. Cleaning and user maintenance shall not be done by children unless they are older than 8 and supervised. Keep the appliance and cable out of reach of children under 8 years. If the cable is damaged, it must be replaced by the manufacturer, its service agent, or someone similarly qualified, to avoid hazard.

 Don't immerse the appliance in liquid.

 The surfaces of the appliance will get hot.

- Leave a space of at least 50mm all round the appliance.
- Don't cover the appliance or put anything on top of it.
- Unplug the appliance when not in use, before moving and before cleaning.
- Don't use the appliance for any purpose other than those described in these instructions.
- Don't operate the appliance if it's damaged or malfunctions.
- Cooking pot is only suitable for gas and electric hobs. Not suitable for induction hobs.
- Do not leave the cooking pot unattended when cooking on the hob

## HOUSEHOLD USE ONLY

### DIAGRAMS

- |                |                |
|----------------|----------------|
| 1. Lid         | 4. Mode switch |
| 2. Cooking pot | 5. Chalk       |
| 3. Handles     |                |

### IMPORTANT

Before writing on your slow cooker with the supplied chalk you must prepare the surface. If you don't do this, the chalk may be difficult to erase afterwards. To condition the surface, rub the writing area of your slow cooker with the side of the chalk to give an even coating (Fig A). Wipe off the coating of chalk with a soft cloth and the surface is now conditioned and ready to use. The exterior of your slow cooker will become hot during use. Only write on your slow cooker before cooking or when it has cooled down.

### THE BENEFITS OF SLOW COOKING

**Health:** The gentle cooking action reduces damage to vitamins and retains more of the nutrients and flavours.

**Economy:** Long, slow cooking can tenderise the cheaper, tougher cuts of meat, and uses about a quarter of the power of the small ring on the average hob.

**Convenience:** Prepare the ingredients the night before, put them in the slow cooker before you leave, and have a delicious meal waiting for you when you get home.

### COOKING MODES

- 1 For traditional slow cooking.
- 2 For "fast cooking". During cooking, make sure the food doesn't dry out. If it looks like drying out, add hot water.

 For keeping food warm – but only after it has been cooked to readiness in the slow cooker.

**CAUTION** Don't use the  setting to heat food up.

# Obsah je uzamčen

**Dokončete, prosím, proces objednávky.  
Následně budete mít přístup k celému dokumentu.**



**Proč je dokument uzamčen? Nahněvat Vás rozhodně nechceme. Jsou k tomu dva hlavní důvody:**

1) Vytvořit a udržovat obsáhlou databázi návodů stojí nejen spoustu úsilí a času, ale i finanční prostředky. Dělali byste to Vy zadarmo? Ne\*. Zakoupením této služby obdržíte úplný návod a podpoříte provoz a rozvoj našich stránek. Třeba se Vám to bude ještě někdy hodit.

*\*) Možná zpočátku ano. Ale vězte, že dotovat to dlouhodobě nelze. A rozhodně na tom nezbohatneme.*

2) Pak jsou tady „roboti“, kteří se přiživují na naší práci a „vysávají“ výsledky našeho úsilí pro svůj prospěch. Tímto krokem se jim to snažíme překazit.

A pokud nemáte zájem, respektujeme to. Urgujte svého prodejce. A když neuspějete, rádi Vás uvidíme!