

**ENG EF-M LENS Instructions**

**EF-M18-150mm f/3.5-6.3 IS STM**

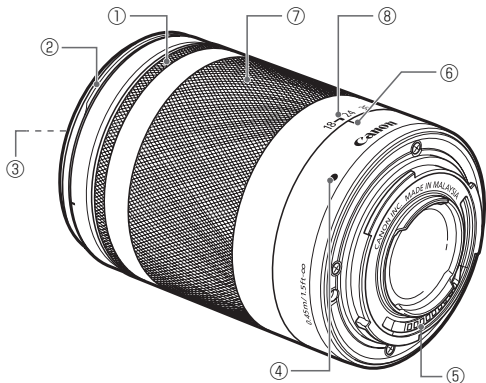

**Nomenclature**

- ① Focusing ring
- ② Hood mount
- ③ Filter mounting thread
- ④ Lens mount index
- ⑤ Contacts
- ⑥ Zoom position index
- ⑦ Zoom ring
- ⑧ Focal length indicator

**Thank you for purchasing a Canon product.**



The Canon EF-M18-150mm f/3.5-6.3 IS STM is a high-magnification zoom lens for use on Canon EOS M Series cameras.

- "IS" stands for Image Stabilizer.
- "STM" stands for stepping motor.

**Camera Firmware**

Please use the latest version of firmware with the camera in use. For details on whether the firmware is the latest version or not, and for details on updating the firmware, please check the Canon website.

**Conventions used in this instruction**

-  Warning to prevent lens or camera malfunction or damage.
-  Supplementary notes on using the lens and taking pictures.

**Safety Precautions**

Precautions to ensure that the camera is used safely. Read these precautions thoroughly. Make sure all details are observed in order to prevent risks and injury to the user and other people.

**Warning** Details pertaining to risks that may result in death or serious injury.

- **Do not look at the sun or a bright light source through the lens.** Doing so could result in vision loss or blindness.
- **Whether it is attached to the camera or not, do not leave the lens under the sun without the lens cap attached.** This is to prevent the lens from concentrating the sun's rays, which could cause a fire.

**Caution** Details pertaining to risks that may result in injury.

- **Do not leave the camera in locations subject to high or low temperatures.** This may result in the camera becoming excessively hot or cold, which may cause burns or other injuries when touched.

**Caution** Details pertaining to risks that may result in damage to property.

- Do not leave the lens in excessive heat such as in a car in direct sunlight. High temperatures can cause the lens to malfunction.

**General Precautions**

**Handling Precautions**

- If the lens is taken from a cold environment into a warm one, condensation may develop on the lens surface and internal parts. To prevent condensation in this case, first put the lens into an airtight plastic bag before taking it from a cold to warm environment. Then take out the lens after it has warmed gradually. Do the same when taking the lens from a warm environment into a cold one.
- Please also read any lens related handling precautions listed in your camera's instruction manual.

This device complies with Part 15 of the FCC Rules. Operation is subject to the following two conditions: (1) This device may not cause harmful interference, and (2) this device must accept any interference received, including interference that may cause undesired operation. Do not make any changes or modifications to the equipment unless otherwise specified in the instructions. If such changes or modifications should be made, you could be required to stop operation of the equipment.

This equipment has been tested and found to comply with the limits for a class B digital device, pursuant to part 15 of the FCC Rules. These limits are designed to provide reasonable protection against harmful interference in a residential installation. This equipment generates, uses and can radiate radio frequency energy and, if not installed and used in accordance with the instructions, may cause harmful interference to radio communications.

However, there is no guarantee that interference will not occur in a particular installation. If this equipment does cause harmful interference to radio or television reception, which can be determined by turning the equipment off and on, the user is encouraged to try to correct the interference by one or more of the following measures:

- Reorient or relocate the receiving antenna.
- Increase the separation between the equipment and receiver.
- Connect the equipment into an outlet on a circuit different from that to which the receiver is connected.
- Consult the dealer or an experienced radio/TV technician for help.

CAN ICES-3 (B) / NMB-3 (B)

**1. Mounting and Detaching the Lens**

See your camera's instructions for details on mounting and detaching the lens.

- After detaching the lens, place the lens with the rear end up to prevent the lens surface and contacts from getting scratched. (fig. ①)
- Contacts that are scratched, soiled, or have fingerprints on them may result in faulty connections or corrosion, which may lead to malfunctions. If the contacts get soiled, clean them with a soft cloth.
- Attach the lens cap and dust cap when disconnecting the lens. When attaching the dust cap, align the lens mount index with the ○ index of the dust cap and rotate in a clockwise direction as shown in the illustration. (fig. ②) Follow the reverse procedure to detach it.

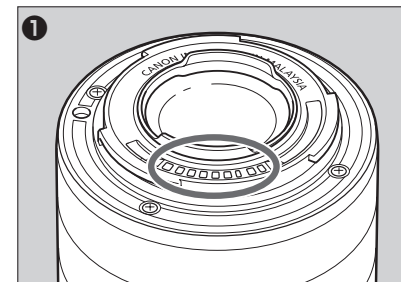

**2. Zooming**

Turn the lens' zoom ring to adjust the size of the photo field or subject. (fig. ③)

- For wide shots, turn the zoom ring toward the wide end.
- For close-ups, turn the zoom ring toward the telephoto end.
- Be sure to finish zooming before focusing. Zooming after focusing can affect the focus.
- Blurring may temporarily occur if the zoom ring is quickly rotated.
- Zooming during still image exposure will result in delayed focus. This causes any streaks of light that are captured during exposure to be blurred.

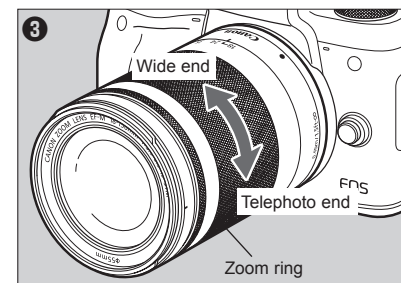
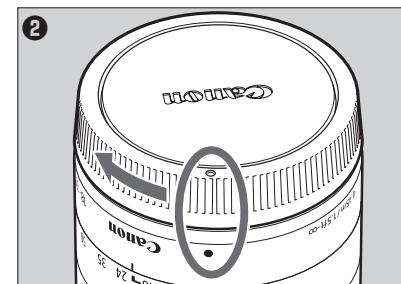

### 3. Manual Focus

When the camera's focus mode is set to [MF], focus manually by turning the focusing ring. (fig. 4)

⚠ Quickly rotating the focusing ring may result in delayed focus.

- Focus mode is set using the camera. Please refer to the camera's instructions.
- After autofocus in [AF+MF] mode, focus manually by pressing the shutter button halfway and turning the focusing ring (full-time manual focusing).

### 4. Image Stabilizer

This lens is equipped with an Image Stabilizer. This function corrects camera shake, allowing users to capture sharp images. Also, the Image Stabilizer automatically provides optimal image stabilization depending on shooting conditions (such as shooting still subjects and following shots). Please set the Image Stabilizer ON or OFF using the camera settings. See your camera's instructions for details.

- ⚠ The Image Stabilizer cannot compensate for a blurred shot caused by a subject that moved.
- The Image Stabilizer may not be fully effective if you shoot from a violently shaking vehicle or other transportation.
- The Image Stabilizer consumes more power than normal shooting, resulting in fewer shots and a shorter movie shooting time.

- When shooting a still subject, it compensates for camera shake in all directions.
- It compensates for vertical camera shake during following shots in a horizontal direction, and compensates for horizontal camera shake during following shots in a vertical direction.
- When you use a tripod, the Image Stabilizer should be turned off to save battery power.
- Even with a monopod, the Image Stabilizer will be as effective as during hand-held shooting. However, depending on the shooting conditions, there are cases in which the Image Stabilizer effect may be less effective.

### ■ Dynamic IS Function (Movie shooting only)

The EF-M18-150mm f/3.5-6.3 IS STM is equipped with dynamic IS, effective when shooting while walking since it expands the IS range.

- Achieves effective IS at the wide end.
- Automatically activates when the camera is set to Movie Shooting.

### 5. Hood (sold separately)

The EW-60F hood cuts out unwanted light and protects the front of the lens from rain, snow, and dust.

To attach the hood, align the hood's attachment position mark with the red dot on the front of the lens, then turn the hood as shown by the arrow until the lens' red dot is aligned with the hood's stop position mark. (fig. 6)

The hood can be reverse-mounted on the lens for storage.

- ⚠ If the hood is not attached properly, vignetting (darkening of the perimeter of the picture) may occur.
- Grasp and rotate the base of the hood when attaching and detaching it. There are cases in which it may become deformed if the hood is rotated with it grasped near to the rim.

### 6. Filters (sold separately)

You can attach filters to the filter mounting thread on the front of the lens.

- ⚠ Only one filter may be attached.

### Specifications

<b>Focal Length/Aperture</b>	18-150mm f/3.5-6.3
<b>Lens Construction</b>	13 groups, 17 elements
<b>Minimum Aperture</b>	f/22-40*
<b>Angle of View</b>	Diagonal: 74°20'-10°25' Vertical: 45°30'-5°45' Horizontal: 64°30'-8°40'
<b>Min. Focusing Distance</b>	at 18 mm: 0.25 m / 0.82 ft. at 50 mm: 0.25 m / 0.82 ft. at 150 mm: 0.45 m / 1.48 ft.
<b>Max. Magnification</b>	at 18 mm: 0.10x at 50 mm: 0.27x at 150 mm: 0.31x
<b>Field of View</b>	at 0.25 m / 0.82 ft.: Approx. 148 x 223 mm / 5.83 x 8.78 in. at 0.45 m / 1.48 ft.: Approx. 48 x 72 mm / 1.89 x 2.83 in.
<b>Filter Diameter</b>	55 mm
<b>Max. Diameter and Length</b>	60.9 x 86.5 mm / 2.40 x 3.41 in.
<b>Weight</b>	Approx. 300 g / 10.6 oz.
<b>Hood</b>	EW-60F (sold separately)
<b>Lens Cap</b>	E-55
<b>Dust Cap</b>	Lens Dust Cap EB
<b>Case</b>	LP816 (sold separately)

- \* Applies to 1/3-stop increments. With 1/2-stop increments, it will be f/22-38.
- Equivalent to 29-240 mm in the 35mm film format.
- The lens length is measured from the mount surface to the front end of the lens. Add 20 mm when including the lens cap and dust cap.
- The size and weight listed are for the lens only, except as indicated.
- Extenders and extension tubes cannot be used with this lens.
- Aperture settings are specified on the camera. The camera automatically compensates for variations in the aperture setting when the camera is zoomed in or out.
- All data listed is measured according to Canon standards.
- Product specifications and appearance are subject to change without notice.

