

 Russell Hobbs



25200-56

 www.russellhobbs.com

- GB
- DE
- FR
- NL
- IT
- ES
- PT
- DK
- SE
- NO
- FI
- RU
- CZ
- SK
- PL
- HR
- SI
- GR
- HU
- TR
- RO
- BG
- AE

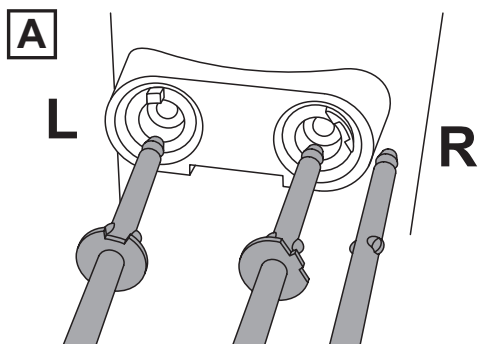
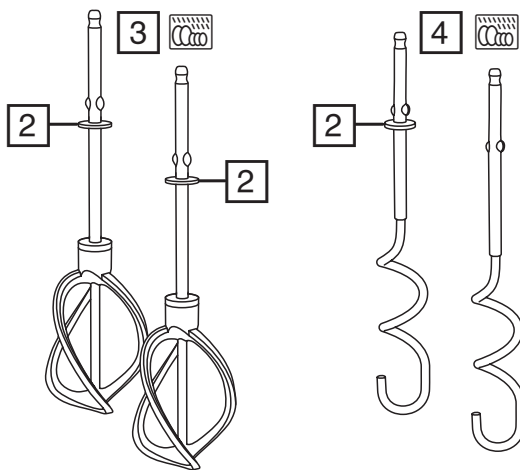
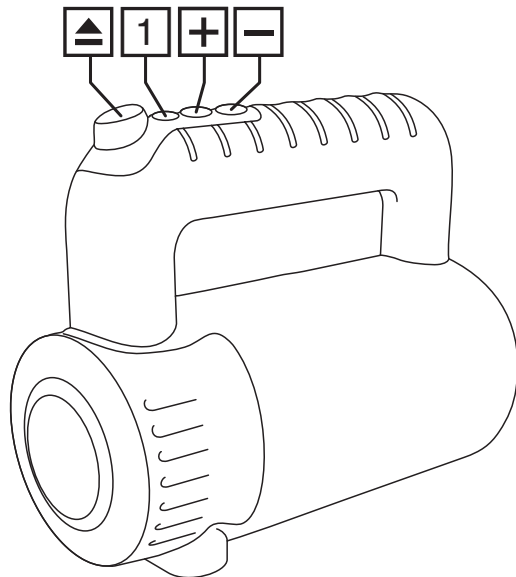

Read the instructions, keep them safe, pass them on if you pass the appliance on. Remove all packaging before use.



IMPORTANT SAFEGUARDS

Follow basic safety precautions, including:

This appliance can be used by persons with reduced physical, sensory or mental capabilities or lack of experience and knowledge if they have been supervised/instructed and understand the hazards involved.

Children must not use or play with the appliance.

Keep the appliance and cable out of reach of children.

Misuse of the appliance may cause injury.

Unplug the appliance before assembly, disassembly, or cleaning.

Don't leave the appliance unattended while plugged in.

If the cable is damaged, it must be replaced by the manufacturer, its service agent, or someone similarly qualified, to avoid hazard.

- ⚠ Do not use this appliance near bathtubs, showers, basins or other vessels containing water.
- Don't use accessories or attachments other than those we supply.
- Don't use the appliance for any purpose other than those described in these instructions.
- Don't use the appliance if it's damaged or malfunctions.
- Don't run the motor continuously for more than 5 minutes, it may overheat. After 5 minutes switch off for at least 5 minutes, to recover. Your mixer will automatically switch off after 5 minutes of continuous use.

HOUSEHOLD USE ONLY

PARTS

- | | |
|------------------|---|
| 1. On/off button | |
| 2. Flange | |
| 3. Whisks | |
| | 4. Hooks |
| |  Dishwasher safe |



FITTING THE WHISKS/HOOKS

1. Switch off (0) and unplug the mixer before fitting or removing the whisks/hooks.
2. Turn each whisk or hook to align the pips on the shaft with the slots in the drive head, then push it into the drive head till it clicks into place.
3. Each whisk/hook must be fitted into a specific drive head (fig. A).
4. Use both whisks or both hooks, don't mix them.

REMOVING THE WHISKS/HOOKS

1. Switch off (0) and unplug the mixer, then shake any excess mixture into the mixing bowl.
2. Hold both whisks/hooks, to prevent them jumping out, and press . This will eject them from the drive heads.

USING THE MIXER

1. Put the plug into the power socket.
2. Press and release the  button. The  button light will flash.

Obsah je uzamčen

Dokončete, prosím, proces objednávky.

Následně budete mít přístup k celému dokumentu.



Proč je dokument uzamčen? Nahněvat Vás rozhodně nechceme. Jsou k tomu dva hlavní důvody:

- 1) Vytvořit a udržovat obsáhlou databázi návodů stojí nejen spoustu úsilí a času, ale i finanční prostředky. Dělali byste to Vy zadarmo? Ne*. Zakoupením této služby obdržíte úplný návod a podpoříte provoz a rozvoj našich stránek. Třeba se Vám to bude ještě někdy hodit.

**) Možná zpočátku ano. Ale vězte, že dotovat to dlouhodobě nelze. A rozhodně na tom nezbohatneme.*

- 2) Pak jsou tady „roboti“, kteří se přiživují na naší práci a „vysávají“ výsledky našeho úsilí pro svůj prospěch. Tímto krokem se jim to snažíme překazit.

A pokud nemáte zájem, respektujeme to. Urgujte svého prodejce. A když neuspějete, rádi Vás uvidíme!