

KENWOOD

KAH359GL
KAH359NS

instructions
istruzioni
instrucciones
Bedienungsanleitungen
gebruiksaanwijzing
Instrukcja obsługi

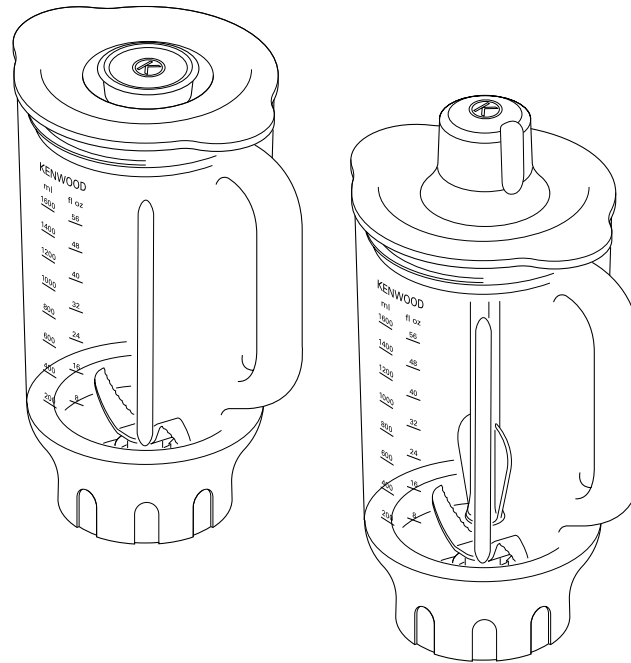

English	2 - 8
Nederlands	9 - 16
Français	17 - 24
Deutsch	25 - 32
Italiano	33 - 40
Português	41 - 48
Español	49 - 56
Dansk	57 - 63
Svenska	64 - 70
Norsk	71 - 77
Suomi	78 - 84
Türkçe	85 - 91
Česky	92 - 98
Magyar	99 - 106
Polski	107 - 114
Русский	115 - 122
Қазақша	123 - 130
Ελληνικά	131 - 138
Slovenčina	139 - 145
Українська	146 - 153
Eesti	154 - 160
Lietuvių	161 - 167
Latviešu	168 - 174
عربي	١٨٠ - ١٧٥

Kenwood Ltd

New Lane
Havant
Hampshire
PO9 2NH

kenwoodworld.com

© Kenwood Ltd 2018



139442/1



English

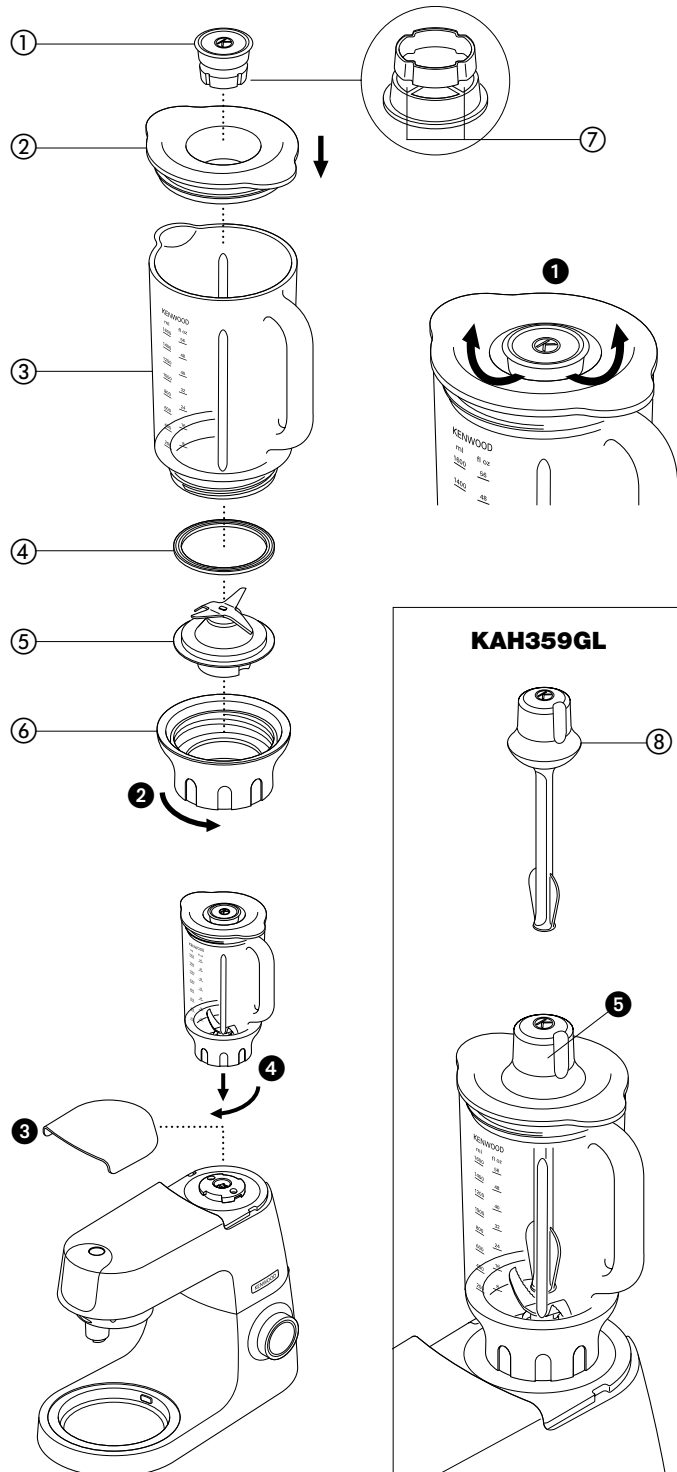

General Safety

- Read these instructions carefully and retain for future reference.
- Remove all packaging and any labels.
- Do not touch the sharp blades. Keep the blade unit away from children.
- Always take care when handling the blade unit and avoid touching the cutting edge of the blades when cleaning.
- Only use the goblet with the base and blade unit supplied.
- Never fit the blade unit to the outlet without the blender goblet fitted.
- Always unplug the machine before putting your hands or utensils in the goblet.
- Switch off and unplug:
 - before fitting or removing parts;
 - after use;
 - before cleaning.
- When removing the blender from the power unit:
 - wait until the blades have completely stopped;
 - do not accidentally unscrew the goblet from the blade unit.
- KAH359GL only: The blender lid must be fitted when using the stir stick in the goblet.
- KAH359GL only: Only use the stir stick ⑧ for processing cold ingredients. **DO NOT** use when processing hot liquids.
- **SCALD RISK:** Hot ingredients must be allowed to cool to room temperature before placing in the goblet or before blending.

- Never run the blender empty.
- Only operate the blender with the lid and filler cap in place.
- Never leave the appliance unattended when it is operating.
- Misuse of your blender can result in injury.
- Never blend more than the maximum capacity stated in the recommended usage chart.
- Never run the blender for longer than one minute - it will overheat. Switch off as soon as you have the right consistency.
- Do not put dry ingredients into the blender before switching on. Cut them into cubes and drop them through the filler cap while the machine is running.
- Do not use the blender as a storage container. Keep it empty before and after use.
- Never blend more than 1600 ml (2 pints 16 fl oz) cold ingredients - less for frothy liquids like milkshakes.
- Smoothie recipes - never blend frozen ingredients that have formed a solid mass during freezing, break it up before adding to the blender.

Refer to your main Kitchen Machine instruction book for additional safety warnings.

Obsah je uzamčen

Dokončete, prosím, proces objednávky.

Následně budete mít přístup k celému dokumentu.



Proč je dokument uzamčen? Nahněvat Vás rozhodně nechceme. Jsou k tomu dva hlavní důvody:

- 1) Vytvořit a udržovat obsáhlou databázi návodů stojí nejen spoustu úsilí a času, ale i finanční prostředky. Dělali byste to Vy zadarmo? Ne*. Zakoupením této služby obdržíte úplný návod a podpoříte provoz a rozvoj našich stránek. Třeba se Vám to bude ještě někdy hodit.

**) Možná zpočátku ano. Ale vězte, že dotovat to dlouhodobě nelze. A rozhodně na tom nezbohatneme.*

- 2) Pak jsou tady „roboti“, kteří se přiživují na naší práci a „vysávají“ výsledky našeho úsilí pro svůj prospěch. Tímto krokem se jim to snažíme překazit.

A pokud nemáte zájem, respektujeme to. Urgujte svého prodejce. A když neuspějete, rádi Vás uvidíme!