

HR FRITEZA NA VRUĆI ZRAK	2	LV AIRFRYER	49	SV LUFTFRITÖS	91
CS ELEKTRICKÁ FRITÉZA	6	LT „AIRFRYER“	54	TR YAĞSIZ FRITÖZ	95
DA AIRFRYER	11	NO AIRFRYER	59	UK МУЛЬТИПІЧ	100
EN AIRFRYER	15	PL FRYTKOWNICA BEZTŁUSZCZOWA		AR مقلاة هوائية	108
ET KUUMAÕHUFRITÜÜR	20		63		
FI ILMAKYPSENNIN	25	RO FRITEUZĂ CU AER	68		
FR FRITEUSE À AIR	29	RU АЭРОГРИЛЬ	73		
DE HEISSLUFTFRITTEUSE	34	SR FRITEZA BEZ ULJA	78		
HU FORRÓLEVÉGŐS SÜTŐ	39	SK AIRFRYER	83		
IT FRIGGITRICE AD ARIA	44	SL AIRFRYER	87		

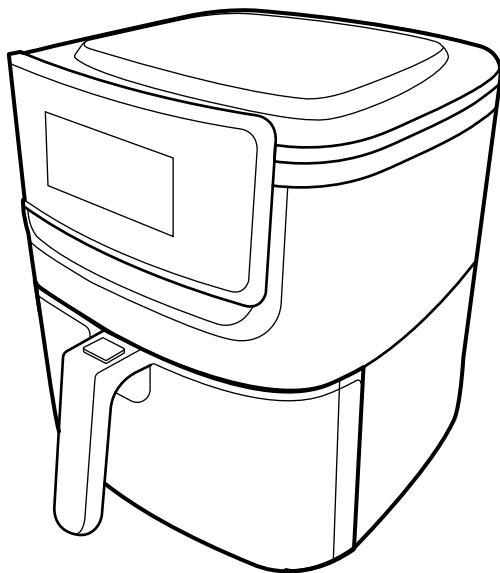

1. OPĆI PREGLED

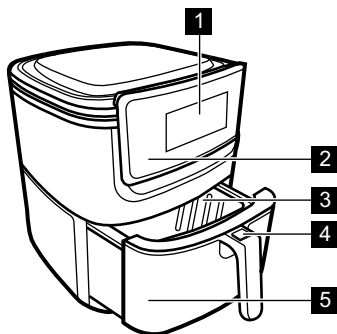





- 1** Zaslón
- 2** Upravljačka ploča
- 3** Košara
- 4** Sigurnosno zaključavanje sa zaštitnim poklopcem
- 5** Plitica

2. UPRAVLJAČKA PLOČA

2.1 Upravljačka ploča

Upoznajte se s osnovnim ikonama na upravljačkoj ploči i zaslonu.

				
UKLJ./ISKLJ.	Gore	Dolje	Temperatura	Trajanje

Pomoć pri kuhanju - kuhanje s automatskim postavkama vremena i temperature.

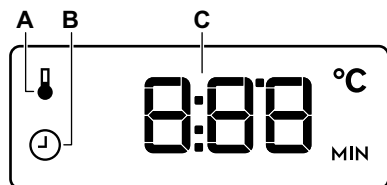

			
Riba	Odrezak	Pileći bataci	Pile
			
Povrće	Pomfrit	Mini pizza	Muffini

2.2 Zaslón



- A.** Postavka temperature
- B.** Postavka vremena
- C.** Vrijeme/temperatura

3. PRIJE PRVE UPORABE

	Uklonite svu ambalažu, naljepnicu i zaštitnu foliju.
	Očistite košaru i posudu toplom vodom, tekućinom za pranje i mekom krpom. Osušite unutarnju i vanjsku stranu uređaja krpom.
	Pri prvoj uporabi, uređaj može ispuštati netoksičan miris koji nestaje odmah. To ne utječe na korištenje.

4. SVAKODNEVNA UPORABA

4.1 Kako koristiti: plitica i košara

Postavite uređaj na stabilnu površinu.

1. Uklonite pliticu i stavite je na stabilnu površinu.
2. Uklonite zaštitni poklopac na sigurnosnoj bravi.
3. Pritisnite sigurnosnu bravu i uklonite košaru.

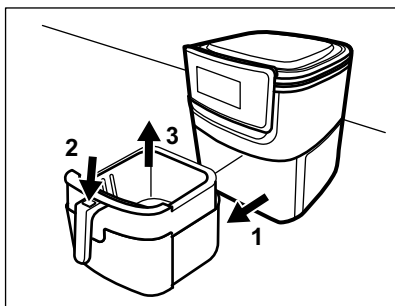

4. U košaru stavite hranu do maksimalne razine. Maksimalna zapremina kkošare je 2 kg.

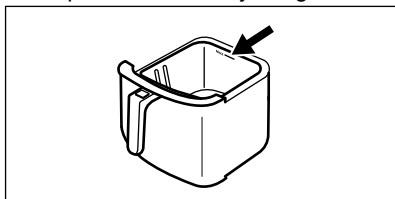









4.2 Kako kuhati

Stavite hranu u košaru. Priključite uređaj na izvor napajanja.

1.  - pritisnite i držite.

2. Odaberite jelo iz Pomoći pri kuhanju:

Simbol	Postavka
	140°C 15 min
	200°C 10 min
	180°C 20 min
	180°C 45 min
	170°C 15 min
	180°C 15 min
	180°C 10 min
	180°C 15 min

3. Pritisnite: .

Po završetku kuhanja, ventilator za hlađenje radi nekoliko sekundi, a zatim se oglašava signal.

Možete promijeniti postavke i isključiti uređaj tijekom kuhanja:

- Za promjenu programa, pritisnite simbol hrane.

Obsah je uzamčen

Dokončete, prosím, proces objednávky.

Následně budete mít přístup k celému dokumentu.



Proč je dokument uzamčen? Nahněvat Vás rozhodně nechceme. Jsou k tomu dva hlavní důvody:

- 1) Vytvořit a udržovat obsáhlou databázi návodů stojí nejen spoustu úsilí a času, ale i finanční prostředky. Dělali byste to Vy zadarmo? Ne*. Zakoupením této služby obdržíte úplný návod a podpoříte provoz a rozvoj našich stránek. Třeba se Vám to bude ještě někdy hodit.

**) Možná zpočátku ano. Ale vězte, že dotovat to dlouhodobě nelze. A rozhodně na tom nezbohatneme.*

- 2) Pak jsou tady „roboti“, kteří se přiživují na naší práci a „vysávají“ výsledky našeho úsilí pro svůj prospěch. Tímto krokem se jim to snažíme překazit.

A pokud nemáte zájem, respektujeme to. Urgujte svého prodejce. A když neuspějete, rádi Vás uvidíme!