



| | | | |
|----|----------------------------|----|--------------------------|
| EN | User manual | LV | Lietotāja rokasgrāmata |
| BG | Ръководство за потребителя | PL | Instrukcja obsługi |
| CS | Příručka pro uživatele | RO | Manual de utilizare |
| ET | Kasutusjuhend | RU | Руководство пользователя |
| HR | Korisnički priručnik | SK | Priručka uživateľa |
| HU | Felhasználói kézikönyv | SL | Uporabniški priročnik |
| KK | Колданушынын нускасы | SR | Korisnički priručnik |
| LT | Vartotojo vadovas | UK | Посібник користувача |

PHILIPS



Specifications are subject to change without notice
© 2013 Koninklijke Philips Electronics N.V.
All rights reserved.



HD9140_EEU_LUM_V1.0

3140 035 36591

English

1 Introduction

Congratulations on your purchase and welcome to Philips! To fully benefit from the support that Philips offers, register your product at www.philips.com/welcome. For recipes to use with your steamer, go to www.philips.com/kitchen.

2 Important

Read this user manual carefully before you use the appliance, and save the user manual for future reference.

Danger

- Never immerse the base in water or rinse it under the tap.

Warning

- Check if the voltage indicated on the appliance corresponds to the local mains voltage before you connect the appliance.
- Only connect the appliance to an earthed wall socket. Always make sure the plug is inserted firmly into the socket.
- Do not use the appliance if the plug, the mains cord or the appliance itself is damaged.
- If the mains cord is damaged, you must have it replaced by Philips, a service centre authorised by Philips or similarly qualified persons in order to avoid a hazard.
- This appliance is not intended for use by persons (including children) with reduced physical, sensory or mental capabilities, or lack of experience and knowledge, unless they have been given supervision or instruction concerning use of the appliance by a person responsible for their safety.
- Children should be supervised to ensure that they do not play with the appliance.
- Keep the mains cord out of the reach of children. Do not let the mains cord hang over the edge of the table or worktop on which the appliance stands.
- Keep the mains cord away from hot surfaces.
- Never steam frozen meat, poultry or seafood. Always thaw these ingredients completely before you steam them.
- Never use the food steamer without the drip tray, otherwise hot water splashes out of the appliance.
- Only use steaming bowls 1, 2 and 3 and the XL steaming bowl in combination with the original base.

Caution

- Never use any accessories or parts from other manufacturers or that Philips does not specifically recommend. If you use such accessories or parts, your guarantee becomes invalid.
- Do not expose the base of the appliance to high temperatures, hot gas, steam or damp heat from other sources than the steamer itself.
- Do not place the food steamer on or near an operating or still hot stove or cooker.
- Always make sure the appliance is off before you unplug it.

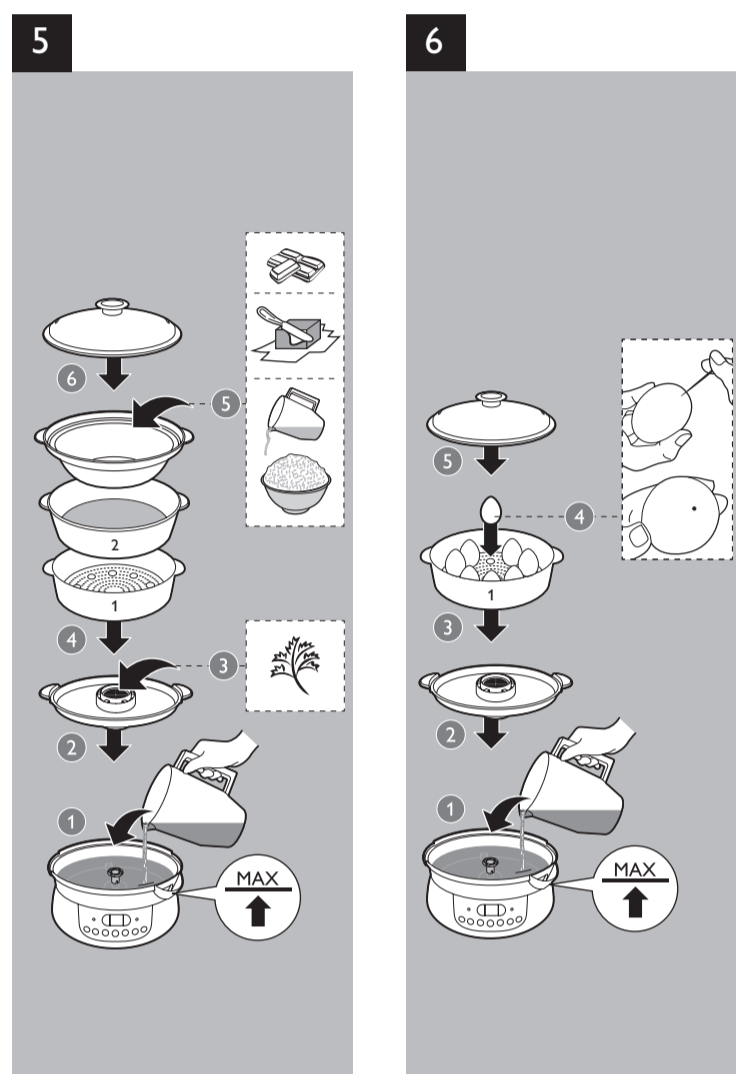
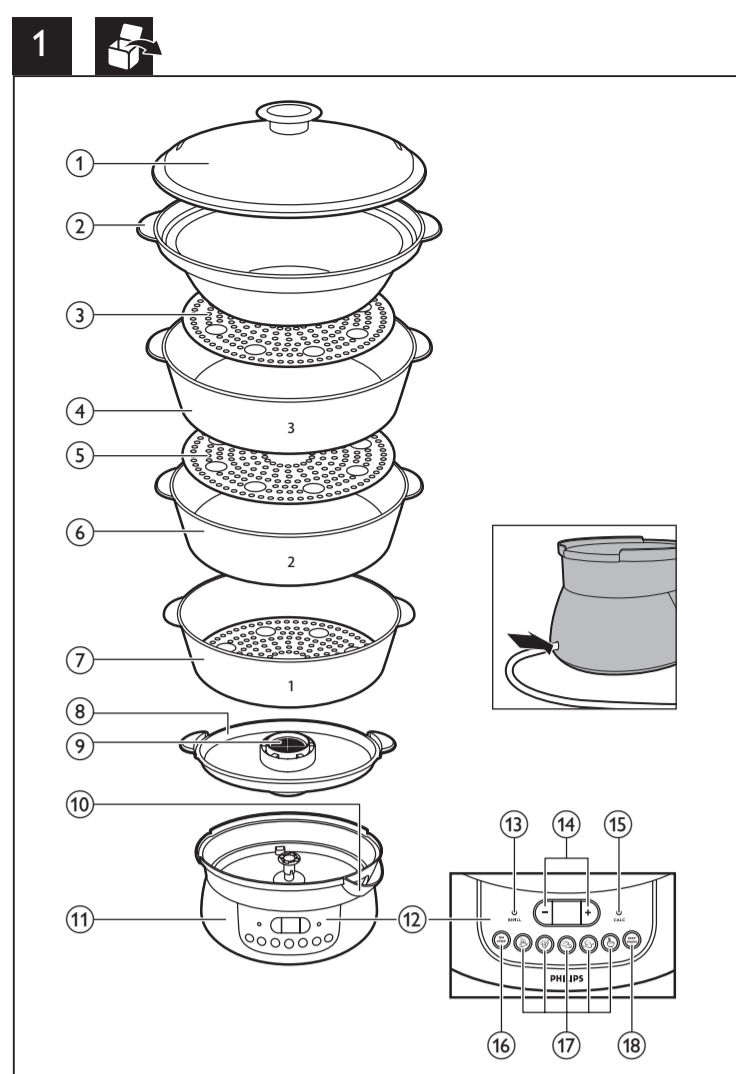

| | Kg (MAX) | (MAX) |
|--|--------------|-----------|
| | 400 g | 13-15 min |
| | 400 g | 16-18 min |
| | 400 g | 16-18 min |
| | 250 g | 30-35 min |
| | 250 g | 10-12 min |
| | 200g 300ml | 40 min |
| | 250 ml | 12-16 min |
| | 6-8 | 15 min |

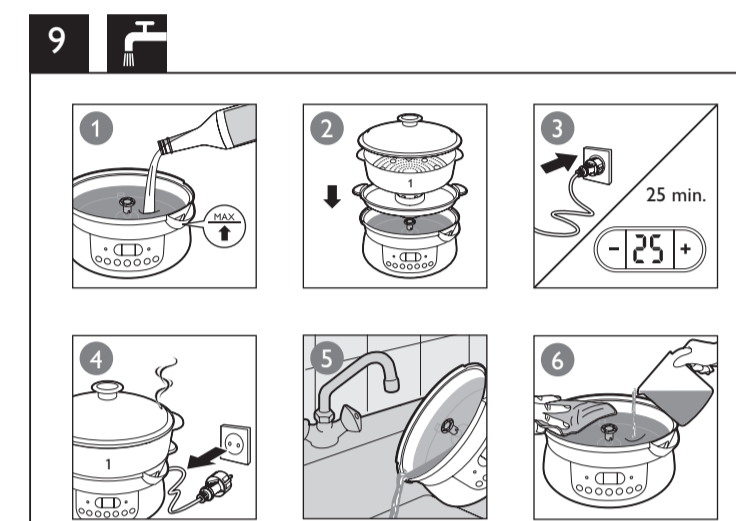
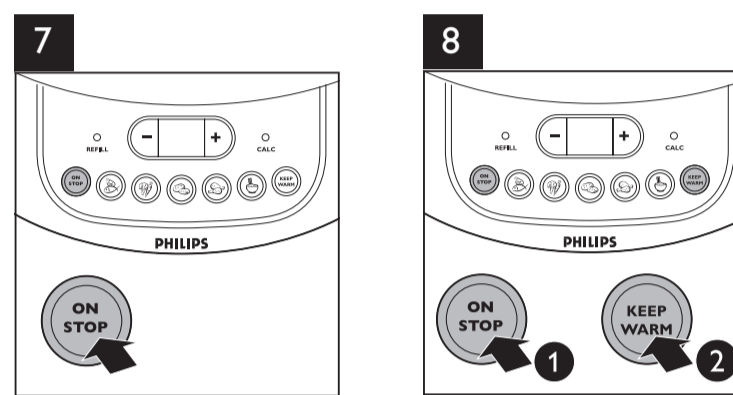
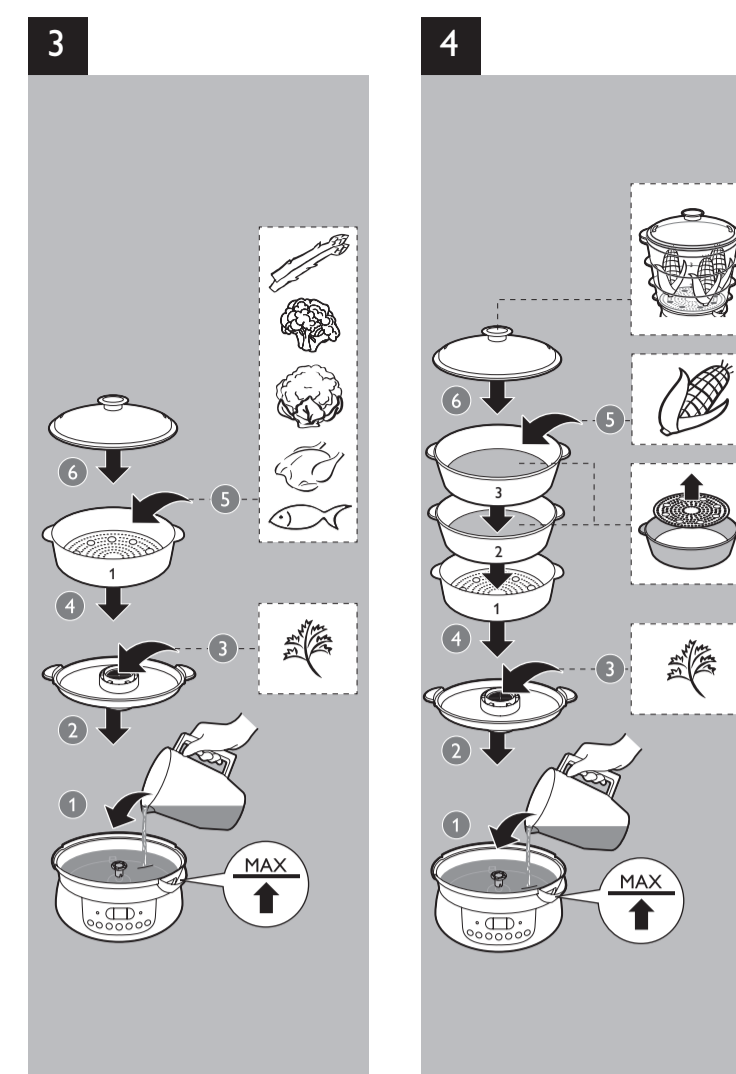

| | Water tap | Washing machine | Dishwasher |
|--|-----------|-----------------|------------|
| | ✓ | ✓ | ✓ |
| | ✓ | ✓ | ✓ |
| | ✗ | ✗ | ✓ |

- Always unplug the appliance and let it cool down before you clean it.
- This appliance is intended for household use only. If the appliance is used improperly or for professional or semi-professional purposes or if it is not used according to the instructions in the user manual, the guarantee becomes invalid and Philips refuses any liability for damage caused.
- Place the food steamer on a stable, horizontal and level surface and make sure there is at least 10cm free space around it to prevent overheating.
- While using steaming bowls 2 and 3 with their removable bottoms, always make sure the rim of the bottom points upwards and that the bottom locks into place ("click").
- Beware of the hot steam that comes out of the food steamer during steaming or when you remove the lid. When you check food, always use kitchen utensils with long handles.
- Always remove the lid carefully and away from you. Let condensation drip off the lid into the food steamer to avoid scalding.
- Always hold the steaming bowls by one of their handles when you stir hot food or remove it from the bowls.
- Always hold the steaming bowls by their handles when the food is hot.
- Do not move the food steamer while it is operating.
- Do not reach over the food steamer while it is operating.
- Do not touch the hot surfaces of the appliance. Always use oven mitts when you handle hot parts of the appliance.
- Do not place the appliance near or underneath objects that would be damaged by steam, such as walls and cupboards.
- Do not operate the appliance in the presence of explosive and/or flammable fumes.
- This appliance is not intended to be operated by means of an external timer or a separate remote-control system.
- There is a small sieve inside the water tank. If the sieve becomes detached, keep it out of the reach of children to prevent them from swallowing it.

Automatic switch-off

The appliance is equipped with automatic shut-off. The appliance switches off automatically if you do not press a button within 2 minutes after plugging in the appliance. The appliance switches off automatically after the set steaming time has elapsed.

Boil-dry protection

This food steamer is equipped with boil-dry protection. The boil-dry protection automatically switches off the appliance if it is switched on when there is no water in the water tank or if the water runs out during use. Let the food steamer cool down for 10 minutes before you use it again.

Electromagnetic fields (EMF)

This Philips appliance complies with all applicable standards and regulations regarding exposure to electromagnetic fields.

Recycling



Your product is designed and manufactured with high quality materials and components, which can be recycled and reused. When you see the crossed-out wheel bin symbol attached to a product, it means the product is covered by the European Directive 2002/96/EC.



Never dispose of your product with other household waste. Please inform yourself about the local rules on the separate collection of electrical and electronic products. The correct disposal of your old product helps prevent potentially negative consequences on the environment and human health.

3 Overview (fig.1)

| | |
|--------------------|------------------------------------|
| ① Lid | ⑩ Water inlet |
| ② XL steaming bowl | ⑪ Base with water tank |
| ③ Removable bottom | ⑫ Control panel |
| ④ Steaming bowl 3 | ⑬ Refill light |
| ⑤ Removable bottom | ⑭ Timer buttons |
| ⑥ Steaming bowl 2 | ⑮ Descaling light |
| ⑦ Steaming bowl 1 | ⑯ On/stop button with light ring |
| ⑧ Drip tray | ⑰ Menu buttons with light rings |
| ⑨ Flavor booster | ⑱ Keep-warm button with light ring |

4 Before first use

Thoroughly clean the parts that come into contact with food before you use the appliance for the first time (see chapter "Cleaning and maintenance"). Wipe the inside of the water tank with a damp cloth.

5 Using the appliance



- Put the appliance on a stable, horizontal and level surface.
- Fill the water tank with water up to the maximum level, with a full water tank, the steamer can steam approximately 1 hour.
- If you want to set a different steaming time than the preset steaming time of the menu buttons, press the menu button with the steaming time that comes closest to the desired steaming time. Then use the + and - timer buttons to increase or decrease the steaming time.



- When you want to steam foods that require various steaming times, set the timer to the longest steaming time. Put the food with the longest steaming time in bowl 1. Steam until the remaining steaming time on the display is equal to the shorter steaming time. Then carefully remove the lid with oven mitts and place bowl 2 containing the ingredients with the shorter steaming time on top of bowl 1. Put the lid on bowl 2 and continue steaming until the set steaming time has elapsed.
- Only fill the water tank with water. Never put seasoning, oil, or other substances in the water tank.
- Food in the top bowl takes usually a little longer to steam than food in the lower bowls.
- If you use ground herbs and spices, rinse the drip tray to wet the flavor booster. This prevents ground herbs or spices from falling through the openings of the flavor booster. If desired, put dried or fresh herbs or spices on the flavor booster to add extra flavor to the food to be steamed.

Food steaming table (fig.2)

The steaming time mentioned in the food table is just an indication. Steaming time may vary depending on the size of the food pieces, the space between the food in the steaming bowl, the amount of food in the bowl, the freshness of the food and your personal preference. If desired, put dried or fresh herbs or spices on the flavor booster to add extra flavor to the food to be steamed.

Steaming food (fig.3, 4 & 5)

Put the food to be steamed in one or more steaming bowls and/or in the XL steaming bowl. You can use the bowl for melting chocolate/butter and cooking rice.

Steaming egg (fig.6)

Put the egg holders to steam eggs conveniently.



- Use a needle to make a small hole on the bottom of the egg before placing it on the egg holder.
- Make sure you place the bowl properly so they do not wobble.

Steaming bowls

You do not have to use all 3 steaming bowls. The steaming bowls are numbered. You can find the number on their handles. The top steaming bowl is No. 3. The middle steaming bowl is No. 2, and the bottom steaming bowl is No. 1. Only stack the steaming bowls in the following order: steaming bowl 1, steaming bowl 2, steaming bowl 3.

Note

- If you use steaming bowls 2 and 3 with their removable bottoms (when using the XL steaming bowl), always make sure the rim of the bottom points upwards and that the bottom locks into place when you hear a click.

Keep-warm mode

The steamer automatically switches to the keep-warm mode after any menu. The food is kept warm for 20 minutes. The light ring round the keep-warm button lights up and the light ring round the menu button goes out.

If you want to keep the food warm longer than 20 minutes, press the on/stop button within 1 minute after the first keep-warm cycle has finished to start another keep-warm cycle. (fig.7) If you want to deactivate the keep-warm mode when it is active, press the on/stop button. If you want to start a keep-warm cycle when the appliance is off or after it has switched off automatically, first press the on/stop button and then the keep-warm button. (fig.8)

Refill light

When the water level in the water tank drops below the MIN level, the refill light flashes and you hear a beep to indicate that you have to refill the water tank.

6 Cleaning and maintenance (fig.9)

Note

- Never use scouring pads, abrasive cleaning agents or aggressive liquids such as petrol or acetone to clean the appliance.
- If the vinegar starts to boil over the edge of the base, unplug the appliance and reduce the amount of vinegar.

Caution

- Do not clean the base in the dishwasher.
- If the sieve in the water tank becomes detached, keep it out of the reach of children to prevent them from swallowing it.
- Never immerse the base in water; nor rinse it under the tap.

Descaling

You have to descale the appliance after it has been used for 15 hours. It is important that you descale the food steamer regularly to maintain optimal performance and to extend the lifetime of the appliance.

- Fill the water tank with white vinegar (8% acetic acid) up to the maximum level.
- Put the drip tray, steaming bowls, and lid on top of the steamer.
- Turn the steaming time adjustment knob to set a steaming time of 25 minutes.
- Let the vinegar cool down completely and empty the water tank. Rinse the water tank with cold water several times.

Note

- Do not use any other kind of descaler.
- Repeat the procedure if there is still some scale in the water tank.

7 Storage

- Make sure all parts are clean and dry before you store the appliance (see chapter "Cleaning and maintenance").
- Make sure the removable bottoms are in place in steaming bowls 2 and 3.
- Place the drip tray on the base.
- Place steaming bowl (3) on the drip tray. Place steaming bowl (2) in steaming bowl (3). Place steaming bowl (1) in steaming bowl (2).
- Place the XL steaming bowl on the other steaming bowls.
- Place the lid on the XL steaming bowl.
- To store the mains cord, push it into the cord storage compartment in the base.

8 Guarantee & service

If you need service or information or if you have a problem, please visit the Philips website at www.philips.com or contact the Philips Consumer Care Center in your country (you can find its phone number in the worldwide guarantee leaflet). If there is no Consumer Care Centre in your country, go to your local Philips dealer.

Obsah je uzamčen

Dokončete, prosím, proces objednávky.

Následně budete mít přístup k celému dokumentu.



Proč je dokument uzamčen? Nahněvat Vás rozhodně nechceme. Jsou k tomu dva hlavní důvody:

- 1) Vytvořit a udržovat obsáhlou databázi návodů stojí nejen spoustu úsilí a času, ale i finanční prostředky. Dělali byste to Vy zadarmo? Ne*. Zakoupením této služby obdržíte úplný návod a podpoříte provoz a rozvoj našich stránek. Třeba se Vám to bude ještě někdy hodit.

**) Možná zpočátku ano. Ale vězte, že dotovat to dlouhodobě nelze. A rozhodně na tom nezbohatneme.*

- 2) Pak jsou tady „roboti“, kteří se přiživují na naší práci a „vysávají“ výsledky našeho úsilí pro svůj prospěch. Tímto krokem se jim to snažíme překazit.

A pokud nemáte zájem, respektujeme to. Urgujte svého prodejce. A když neuspějete, rádi Vás uvidíme!