

VR415; VR420; VR425 Class A Double Block Valves

PRODUCT DATA

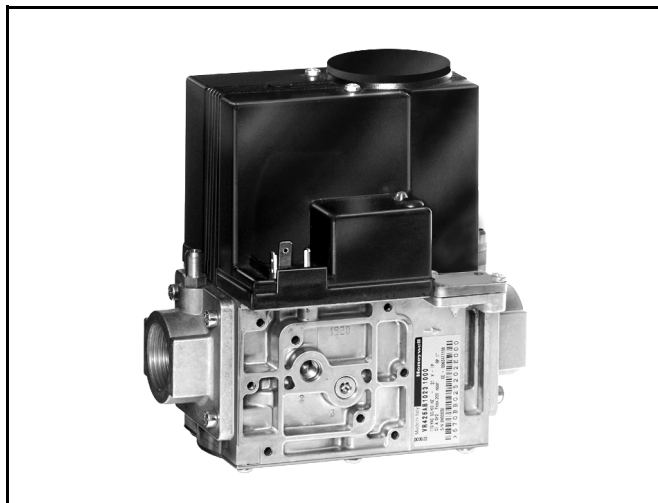

APPLICATION

The VR415/VR420/VR425 Class A Double Block Valves are used for control of gaseous fuels in gas-fired power burners, atmospheric gas boilers, ovens, furnaces, incinerators, roof-top units, makeup air units and other gas consuming appliances.

FEATURES

- Class A double block for control of gaseous fuels in gas consuming appliances in accordance with international standards.
- Main body with two single-seat shutoff valves.
- Provides for mounting optional flanged pressure switches.
- Closing time: < 1 second.
- Coils suitable for permanent energization.
- Fine mesh screen (strainer) between inlet flange and main body.
- Various pressure tap points at main body available, when no additional valves or pressure switches are used.
- Plug connector according to DIN 43650.
- CSA Rated for 1/2 psi (34.5 mBar).
- Maximum operating pressure 2.9 psi (200 mBar).

Contents

Application	1
Features	1
Specifications	2
Ordering Information	2
Installation	3
Adjustments and Final Checkout	4
Operation	5
Troubleshooting	5
Service Information	6



SPECIFICATIONS

The specifications in this section are related to the main valve. The valve must be used in combination with a burner control.

Model:

VR415NA1001 1/2 in. (13 mm).
 VR420NA1004 3/4 in. (19 mm).
 VR425NA1009 1 in. (25 mm).

Pipe Size: Inlet and outlet straight flange connection.

Capacity: See Table 1 for capacity curves.

Table 1. Gas Capacity (cfh).

Valve Model	Capacity (cfh), 0.64 sp. gr. gas @ 1 in. w.c. Δ P
VR415	185
VR420	300
VR425	425

Maximum Operating Pressure:
 2.9 psi (200 mbar).

NOTE: CSA certifies for 1/2 psi (34.5 mbar).

Connections:

1/8 in. (3 mm) pressure taps at inlet and outlet flanges. Eight flange connections are provided at the main body to mount either a pressure switch (low or high) or a Valve Proving System (VPS).

Torsion and Bending Stress: Pipe connections meet EN161, Group 2, requirements.

CSA Certificate Number: 158158-1227192.

Valve Classification: Class A + A, per EN 126/EN 161.

Supply Voltage: 120 Vac (+10%, -15%), 50/60 Hz (±10%).

Electrical Equipment: Dc current coils with combined rectifier inside the cover.

Electrical Connection: Standard DIN plug connector.

Ambient Temperature Range: 5°F to 140°F (-15°C to +60°C).

Coil Insulation Solenoid Valves: Class F insulation material.

Enclosure: IP 54 (NEMA 3).

Body Material: Aluminum alloy, die cast.

Strainer: Fine mesh screen (.0135 in. [0.34 mm] diameter), AISI 303 steel, serviceable after removing inlet flange screws. Meets EN 161 requirements for strainers.

Seals and Gaskets: Hydrocarbon resistant NBR and Viton rubber types.

Flange Kit: Consists of one flange with sealing plug, 1 O-ring and four screws.

Table 2. Power Consumption in Watts at 120 Vac.

Model	V1 + V2	
	W	mA
VR415	32	150
VR420	32	150
VR425	38	180

Opening Time:

Dead time maximum: 1 second.
 First valve opening: < 1 second.
 Second valve opening: < 1 second.

Maximum Allowable Leakage:

Outerwall: 3 cu. in./hr (50 cm³/h) at test pressure of 0.087 psi (6 mbar) and 7.83 psi (540 mbar).
 First valve: 2.4 cu. in./hr, (40 cm³/h) at test pressure of 0.087 psi (6 mbar) and 7.83 psi (540 mbar).
 Second valve: 2.4 cu. in./hr (40 cm³/h) at test pressure of 0.087 psi (6 mbar) and 7.83 psi (540 mbar).

High Pressure Test: In the Off condition, the valve will withstand 21.75 psi (1.5 bar) inlet pressure without damage.

NOTE: Attempts to operate the valve while in this condition will not cause damage.

ORDERING INFORMATION

When purchasing replacement and modernization products from your TRADELINE® wholesaler or distributor, refer to the TRADELINE® Catalog or price sheets for complete ordering number.

If you have additional questions, need further information, or would like to comment on our products or services, please write or phone:

1. Your local Home and Building Control Sales Office (check white pages of your phone directory).
2. Home and Building Control Customer Relations
 Honeywell, 1885 Douglas Drive North
 Minneapolis, Minnesota 55422-4386

In Canada—Honeywell Limited/Honeywell Limitée, 35 Dynamic Drive, Scarborough, Ontario M1V 4Z9.

International Sales and Service Offices in all principal cities of the world. Manufacturing in Australia, Canada, Finland, France, Germany, Japan, Mexico, Netherlands, Spain, Taiwan, United Kingdom, U.S.A.

Closing Time: Less than 1 second for all valves.

Maximum Working Frequency: One cycle per minute.

Duty Cycle: Coil suitable for permanent energization in cooperation with ignition controller.

Operational Voltage Range: The combination gas valve will function satisfactorily between 85% and 110% of the rated voltage.

Design Life: 500,000 cycles.

Dimensions: See Fig. 1.

Approvals:

Gas Appliance Directive 90.396/EEC.

PIN: 0063AT1198.

Low Voltage Directive: 73/23/EEC.

Electro Magnetic Compatibility Directive: 89/336/EEC.

CSA: File: 158158-0001227192, Guide 3371-03, 3371-83.

Underwriters Laboratories, Inc. (UL):

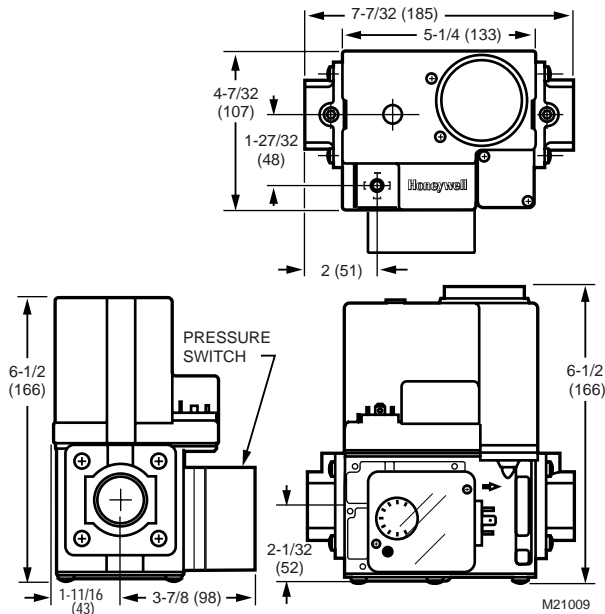

Fig. 1. Approximate dimensions of VR415/VR420 in in. (mm).

INSTALLATION

When Installing this Product...

1. Read these instructions carefully. Failure to follow them could damage the product or cause a hazardous condition.
2. Check the ratings given in the instructions and on the product to make sure the product is suitable for your application.
3. The installer must be a trained, experienced flame safeguard technician.
4. After installation is complete, check out product operation as provided in these instructions.

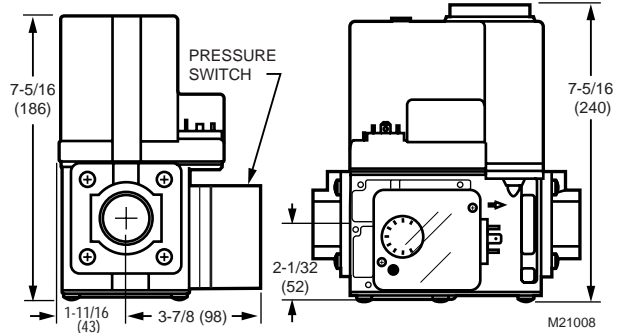
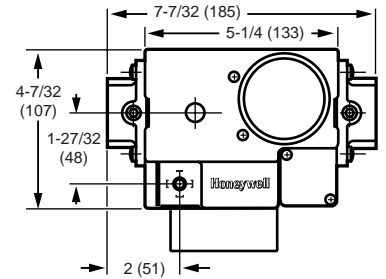

Fig. 2. Approximate dimensions of VR425 in in. (mm).

⚠ WARNING

Fire or Explosion Hazard.

Can cause serious injury, death or property damage.

1. Turn off the gas supply before beginning installation.
2. Disconnect power supply to the valve actuator before beginning installation to prevent electrical shock and damage to the equipment.
3. Do not remove the seal over the valve inlet and outlet until ready to connect piping.
4. The valve must be installed so that the arrow on the valve points in the direction of the gas flow, so that gas pressure helps to close the valve.

Mounting Position

The gas valve can be mounted plus or minus 90 degrees from the vertical.

Mounting locations

The distance between the gas valve and the wall/ground must be a minimum of 11-5/16 in. (30 cm).

Main Gas Connection

1. Take care that dirt does not enter the gas valve during handling.
2. Remove the flanges from the valves.
3. Use new, properly reamed, pipe, free from chips.
4. Do not thread pipe too far into valve. Valve distortion or malfunction can result from excess pipe in the valve.
5. Make sure O-ring sealing surfaces are clean.
6. Apply a moderate amount of good quality pipe dope, resistant to the action of liquid propane (LP) gas only on the pipe threads.
7. Screw the flanges onto the pipes.

Obsah je uzamčen

Dokončete, prosím, proces objednávky.

Následně budete mít přístup k celému dokumentu.



Proč je dokument uzamčen? Nahněvat Vás rozhodně nechceme. Jsou k tomu dva hlavní důvody:

- 1) Vytvořit a udržovat obsáhlou databázi návodů stojí nejen spoustu úsilí a času, ale i finanční prostředky. Dělali byste to Vy zadarmo? Ne*. Zakoupením této služby obdržíte úplný návod a podpoříte provoz a rozvoj našich stránek. Třeba se Vám to bude ještě někdy hodit.

**) Možná zpočátku ano. Ale vězte, že dotovat to dlouhodobě nelze. A rozhodně na tom nezbohatneme.*

- 2) Pak jsou tady „roboti“, kteří se přiživují na naší práci a „vysávají“ výsledky našeho úsilí pro svůj prospěch. Tímto krokem se jim to snažíme překazit.

A pokud nemáte zájem, respektujeme to. Urgujte svého prodejce. A když neuspějete, rádi Vás uvidíme!