



hama[®]

THE SMART SOLUTION

00
186414

Bathroom Clock

Badezimmeruhr

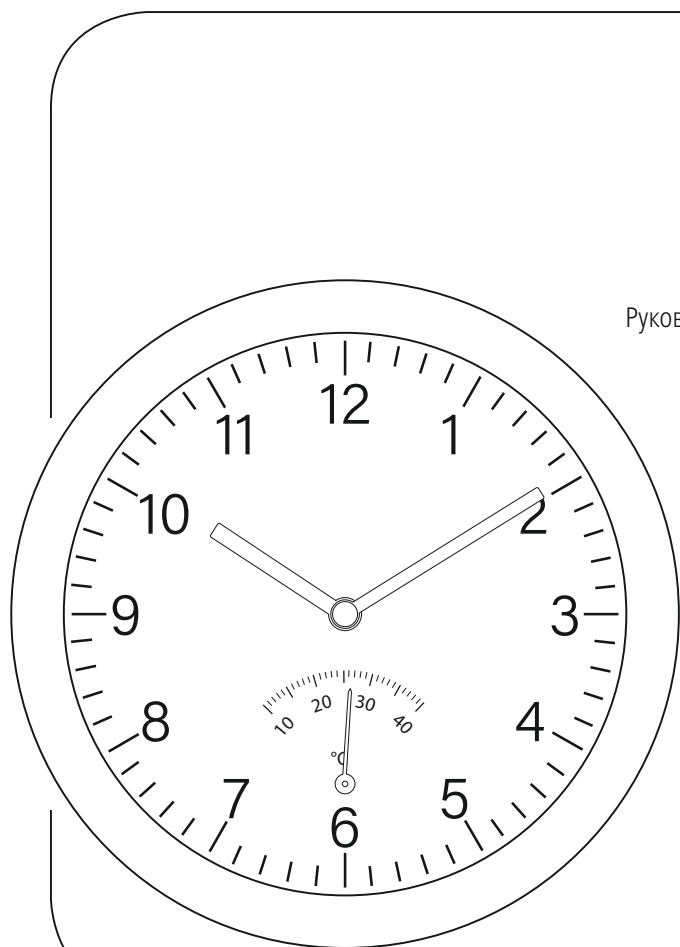

Operating Instructions

Bedienungsanleitung

Mode d'emploi

Instrucciones de uso

Руководство по эксплуатации

Istruzioni per l'uso

Gebruiksaanwijzing

Οδηγίες χρήσης

Instrukcja obsługi

Használati útmutató

Návod k použití

Návod na použitie

Manual de instruções

Manual de utilizare

Bruksanvisning

Käyttöohje

Работна инструкция

GB

D

F

E

RUS

I

NL

GR

PL

H

CZ

SK

P

RO

S

FIN

BG

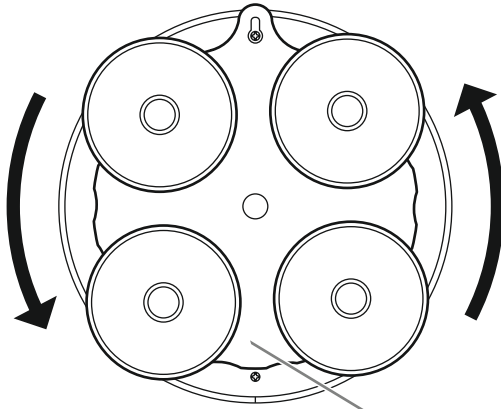

1

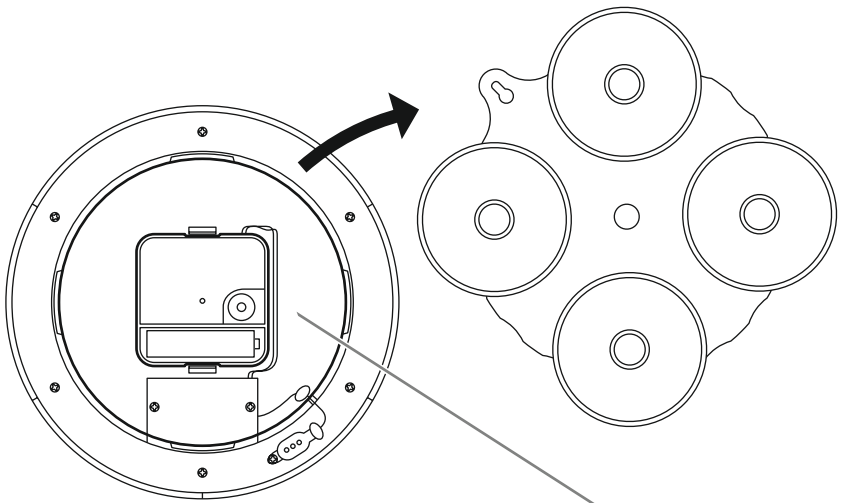

2

Controls and Displays

1. Back case
2. Battery compartment

1. Explanation of Warning Symbols and Notes

Warning



This symbol is used to indicate safety instructions or to draw your attention to specific hazards and risks.

Note



This symbol is used to indicate additional information or important notes.

2. Package Contents

- Wall clock
- 1 (AA) battery
- These operating instructions

3. Safety Notes

- Protect the product from dirt, moisture and overheating, and only use it in a dry environment.
- Do not use the product in areas where the use of electronic devices is not permitted.
- Do not drop the product and do not expose it to any major shocks.
- Do not modify the product in any way. Doing so voids the warranty.
- Keep the packaging material out of the reach of children due to the risk of suffocation.
- Dispose of packaging material immediately according to locally applicable regulations.
- The product is intended for private, non-commercial use only.
- Use the product for its intended purpose only.
- Do not use the product in the immediate vicinity of heaters or other heat sources or in direct sunlight.
- Do not operate the product outside the power limits given in the specifications.
- Do not open the device or continue to operate it if it becomes damaged.
- Do not attempt to service or repair the product yourself. Leave any and all service work to qualified experts.
- Keep this product, as all electrical products, out of the reach of children!
- Use the item only in moderate climatic conditions.

Warning – Batteries



- When inserting batteries, note the correct polarity (+ and - markings) and insert the batteries accordingly. Failure to do so could result in the batteries leaking or exploding.
- Only use batteries (or rechargeable batteries) that match the specified type.
- Before you insert the batteries, clean the battery contacts and the polar contacts.
- Do not allow children to change batteries without supervision.
- Do not mix old and new batteries or batteries of a different type or make.
- Remove the batteries from products that are not being used for an extended period (unless these are being kept ready for an emergency).
- Do not short-circuit batteries.
- Do not charge batteries.
- Do not throw batteries in a fire.
- Keep batteries out of the reach of children.
- Never open, damage or swallow batteries or allow them to enter the environment. They can contain toxic, environmentally harmful heavy metals.
- Immediately remove and dispose of dead batteries from the product.
- Avoid storing, charging or using the device in extreme temperatures and extremely low atmospheric pressure (for example, at high altitudes).

4. Getting Started

4.1 Inserting the battery

- Remove the cover (1) of the product.
- Remove the battery that was already inserted into the clock, remove the protective film if necessary as well as the contact interrupter and the re-insert the battery with the correct polarity.
- The clock is ready for operation.

4.2. Replacing the battery

- Remove the cover (1) of the product.
- Remove and dispose of any used batteries. Insert the new battery (AA). Ensure that the polarity of the battery corresponds to the symbols in the battery compartment.
- Attach the cover (1) of the product.

5. Installation

- You can use the suction cups on any glass surfaces, including mirrors, glass or tiles. Moisten the suction cups before attaching the clock for a more secure hold. Ensure that there is no dust or grease on the surface on which you want to attach the suction cups. The suction cups could loosen over time; to prevent the clock from falling, press the suction cups against the wall every now and then to ensure that the clock remains fixed on the wall. Attach the clock to the wall in an area where it will not be damaged if it should fall.
- The clock is also equipped with a slot for wall mounting on the back side, so that you can attach it to the wall using a nail or a screw.

Warning – Mounting Note



- Before mounting the clock, ensure that the chosen wall is suitable for the weight to be mounted, and make sure that there are no electrical wires, water, gas or other lines at the installation site on the wall.
- Purchase special fastening materials from specialised dealers.
- Do not mount the product above locations where persons might linger.

6. Operation

- Once the battery has been inserted properly, the clock will automatically start running.
- Use the setting wheel on the back of the clock to set the time.

7. Care and Maintenance

Only clean this product with a slightly damp, lint-free cloth and do not use aggressive cleaning agents. Make sure that water does not get into the product.

8. Warranty Disclaimer

Hama GmbH & Co KG assumes no liability and provides no warranty for damage resulting from improper installation/mounting, improper use of the product or from failure to observe the operating instructions and/or safety notes.

9. Technical Data

Wall clock



| | |
|--------------|-------------------------|
| Power supply | 1.5 V 1 x AA battery |
|--------------|-------------------------|

10. Recycling Information

Note on environmental protection:



After the implementation of the European Directive 2012/19/EU and 2006/66/EU in the national legal system, the following applies: Electric and electronic devices as well as batteries must not be disposed of with household waste. Consumers are obliged by law to return electrical and electronic devices as well as batteries at the end of their service lives to the public collecting points set up for this purpose or point of sale. Details to this are defined by the national law of the respective country. This symbol on the product, the instruction manual or the package indicates that a product is subject to these regulations. By recycling, reusing the materials or other forms of utilising old devices/batteries, you are making an important contribution to protecting our environment.

Obsah je uzamčen

Dokončete, prosím, proces objednávky.

Následně budete mít přístup k celému dokumentu.



Proč je dokument uzamčen? Nahněvat Vás rozhodně nechceme. Jsou k tomu dva hlavní důvody:

- 1) Vytvořit a udržovat obsáhlou databázi návodů stojí nejen spoustu úsilí a času, ale i finanční prostředky. Dělali byste to Vy zadarmo? Ne*. Zakoupením této služby obdržíte úplný návod a podpoříte provoz a rozvoj našich stránek. Třeba se Vám to bude ještě někdy hodit.

**) Možná zpočátku ano. Ale vězte, že dotovat to dlouhodobě nelze. A rozhodně na tom nezbohatneme.*

- 2) Pak jsou tady „roboti“, kteří se přiživují na naší práci a „vysávají“ výsledky našeho úsilí pro svůj prospěch. Tímto krokem se jim to snažíme překazit.

A pokud nemáte zájem, respektujeme to. Urgujte svého prodejce. A když neuspějete, rádi Vás uvidíme!