

## Overview

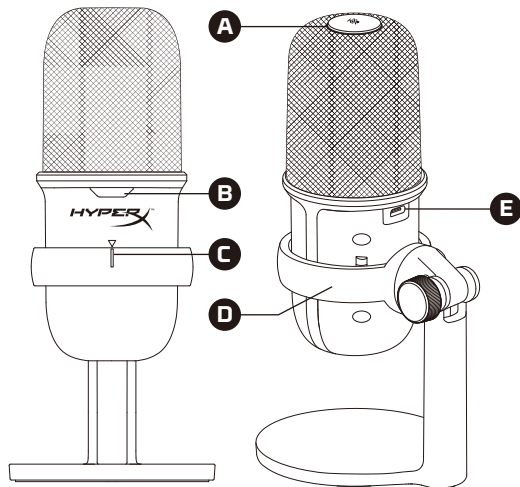

**F**



- A** Tap-to-mute sensor
- B** Microphone status LED
- C** Microphone alignment guide
- D** Microphone stand
- E** USB-C port
- F** USB cable

## Using PC or PS4

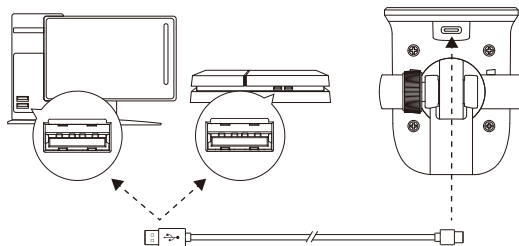

## Microphone Position

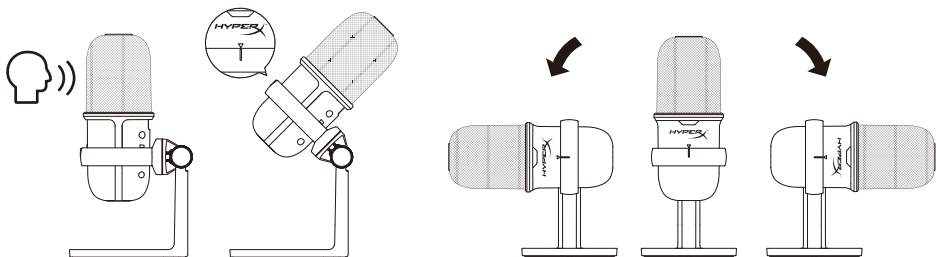

SoloCast should be placed with the front of the microphone facing the sound source. This is indicated by the alignment guide on both the microphone and the stand.

SoloCast can be rotated to allow for easy placement under a monitor.

## Muting the Microphone

Tap the top of the microphone to mute/unmute the microphone. The microphone status LED will flash when the mute is enabled.

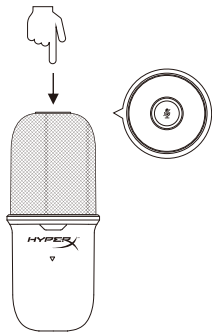

## Using a Microphone Mount

SoloCast can be removed from its stand and used with microphone mounts with either 3/8" or 5/8" threads.

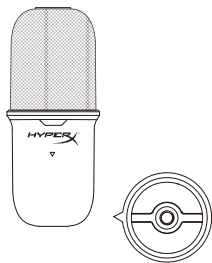

## Questions or Setup Issues?

Contact the HyperX support team or see user manual at: [hyperxgaming.com/support/microphones](https://hyperxgaming.com/support/microphones)

# Obsah je uzamčen

**Dokončete, prosím, proces objednávky.**

**Následně budete mít přístup k celému dokumentu.**



**Proč je dokument uzamčen? Nahněvat Vás rozhodně nechceme. Jsou k tomu dva hlavní důvody:**

- 1) Vytvořit a udržovat obsáhlou databázi návodů stojí nejen spoustu úsilí a času, ale i finanční prostředky. Dělali byste to Vy zadarmo? Ne\*. Zakoupením této služby obdržíte úplný návod a podpoříte provoz a rozvoj našich stránek. Třeba se Vám to bude ještě někdy hodit.

*\*) Možná zpočátku ano. Ale vězte, že dotovat to dlouhodobě nelze. A rozhodně na tom nezbohatneme.*

- 2) Pak jsou tady „roboti“, kteří se přiživují na naší práci a „vysávají“ výsledky našeho úsilí pro svůj prospěch. Tímto krokem se jim to snažíme překazit.

A pokud nemáte zájem, respektujeme to. Urgujte svého prodejce. A když neuspějete, rádi Vás uvidíme!